

# DPA Amplifier



## Quick Start Guide

### EXPLANATION OF TERMS AND SYMBOLS

The term "**WARNING!**" indicates instructions regarding personal safety. If the instructions are not followed the result may be bodily injury or death.

The term "**CAUTION!**" indicates instructions regarding possible damage to physical equipment. If these instructions are not followed, it may result in damage to the equipment that may not be covered under the warranty.

The term "**IMPORTANT!**" indicates instructions or information that are vital to the successful completion of the procedure.

The term "**NOTE**" is used to indicate additional useful information.



The intent of the lightning flash with arrowhead symbol in a triangle is to alert the user to the presence of un-insulated "dangerous" voltage within the product's enclosure that may be of sufficient magnitude to constitute a risk of electric shock to humans.



The intent of the exclamation point within an equilateral triangle is to alert the user to the presence of important safety, and operating and maintenance instructions in this manual.



**NOTE:** This Quick Start Guide is based on the basic configuration as the amplifier comes from the factory. Four separate inputs, and four separate outputs. For detailed instructions for custom configurations refer to the DPA User Guide (TD-000367).

### Rack-Mount the Amplifier

1. Secure the amplifier in the rack with eight screws (not supplied), four in front, four in back.

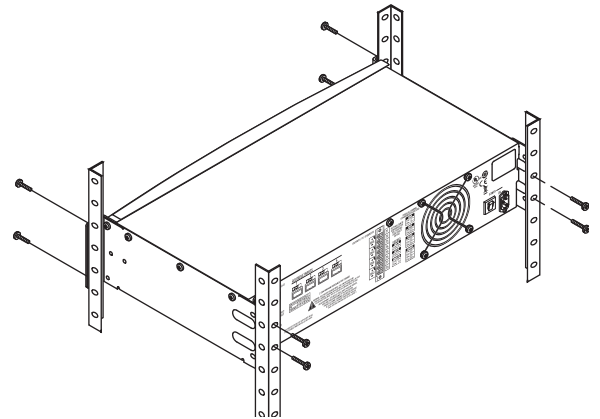

– Figure 1 –

TD-000433-00-A



# Connections

## Inputs

1. Wire the audio line-level source to up to four Euro-style connectors (supplied). You may use either balanced inputs (Figure 2) or unbalanced inputs (Figure 3).
2. Plug the connectors into the appropriate receptacles (Routable Inputs 1, 2, 3, 4) Figure 4.
3. Connect the IEC power cord to the AC receptacle on the rear of the amplifier. (Figure 5)

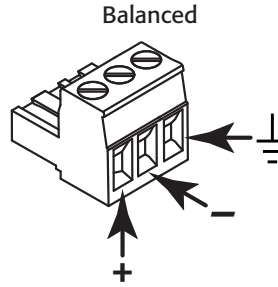

– Figure 2 –

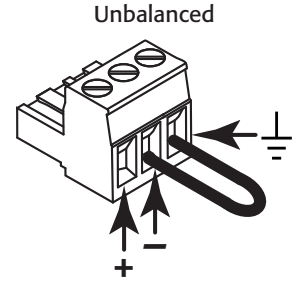

– Figure 3 –

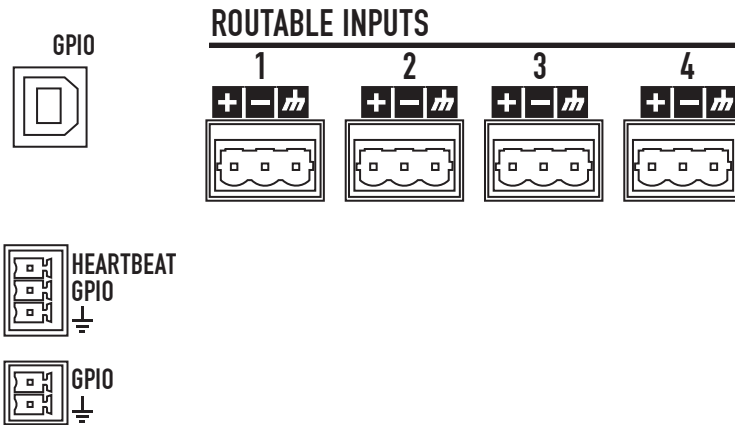

– Figure 4 –

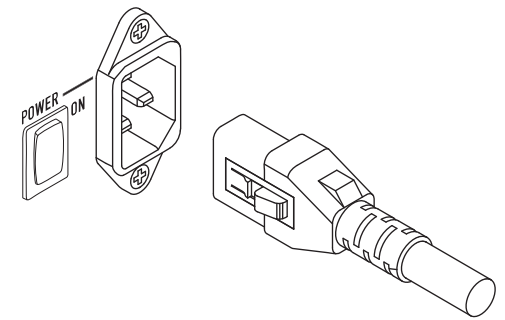

– Figure 5 –



**WARNING!** Do not turn the amplifier on at this time.

## Outputs

When the output configuration of the amplifier changes, the Outputs to the loudspeakers change accordingly. Use the diagrams shown in Figure 6 thru Figure 8 as a reference for wiring the loudspeakers. After connecting the outputs to the loudspeakers, you may turn the amplifier on.

### Separate Channels (A B C D)

#### For Four Separate Loudspeakers

Use four 2-wire cables, connect to:

- T1+/T2- (Loudspeaker 1)
- T3+/T4- (Loudspeaker 2)
- T5+/T6- (Loudspeaker 3)
- T7+/T8- (Loudspeaker 4)

A	B	C	D
8.0	8.0	8.0	8.0
625	625	625	625
625	625	625	625

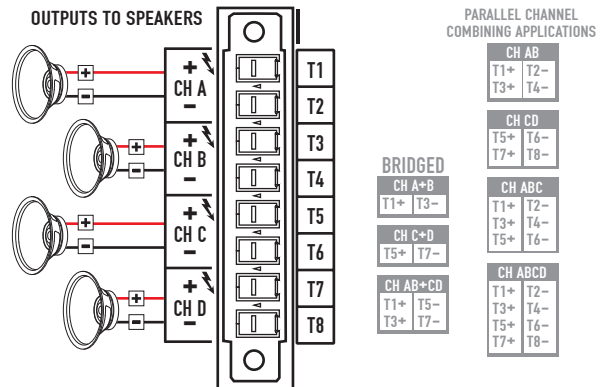

– Figure 6 –

## Bridged (A+B) and Separate (C D) Channels

### For A+B (Bridged) One Loudspeaker

Use one 2-wire cable connect to:

- T1+/T3-

### For C & D (Separate) Two Loudspeakers

Use two 2-wire cables connect to:

- T5+/T6- for CH C
- T7+/T8- for CH D

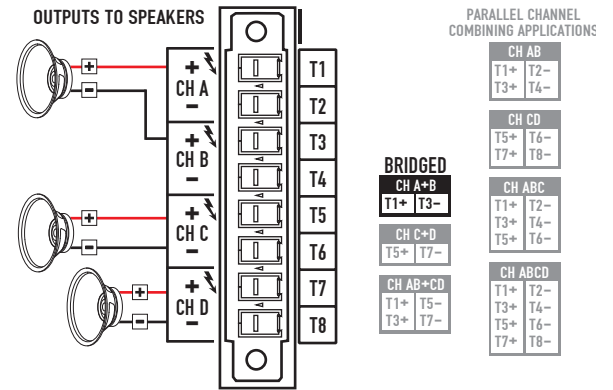
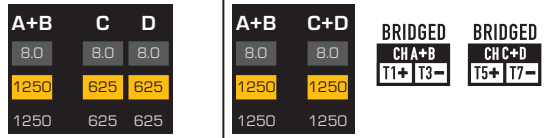

– Figure 7 –

## Parallel Channels (ABCD)

### For One Loudspeaker

Full power to one loudspeaker

Use one 2-wire cable, connect to:

- T1+/T2-
- Jumper T1, T3, T5, T7
- Jumper T2, T4, T6, T8

### For Multiple Loudspeakers

Full power for multiple loudspeakers in parallel

Use up to four 2-wire cables, connect to:

- T1+/T2-
- T3+/T4-
- T5+/T6-
- T7+/T8-

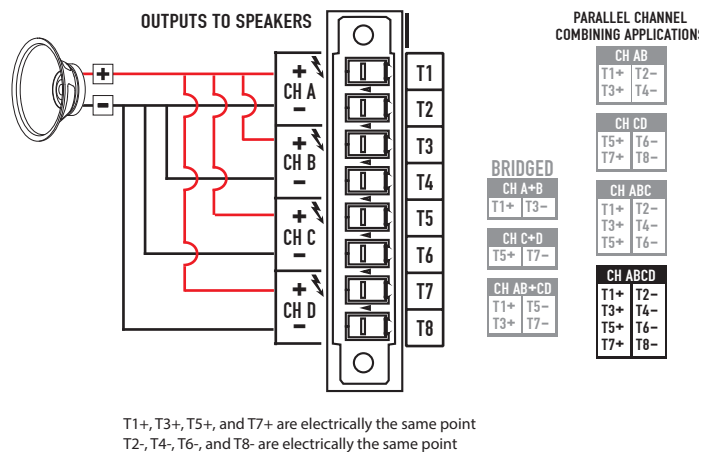

– Figure 8 –

## Connect the Loudspeakers

1. Connect the loudspeaker wiring to the 8-pin Euro-style connector as needed for your amplifier's configuration.
2. Install the female 8-pin Euro-style connector onto the male connector on the rear of the amplifier as shown in Figure 9.
3. Use a Phillips screwdriver to secure the connector.

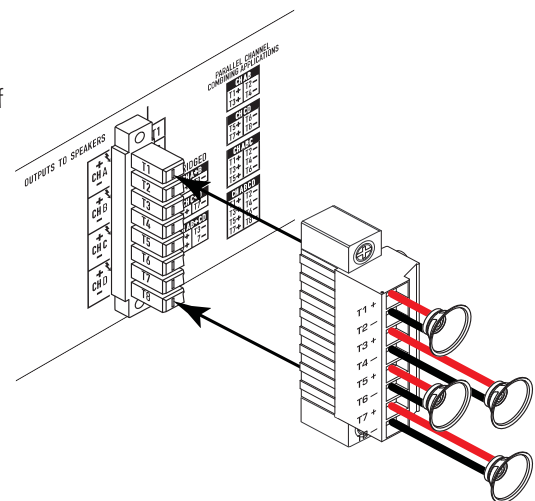

– Figure 9 –

# DPA Amplifier Signal Flow

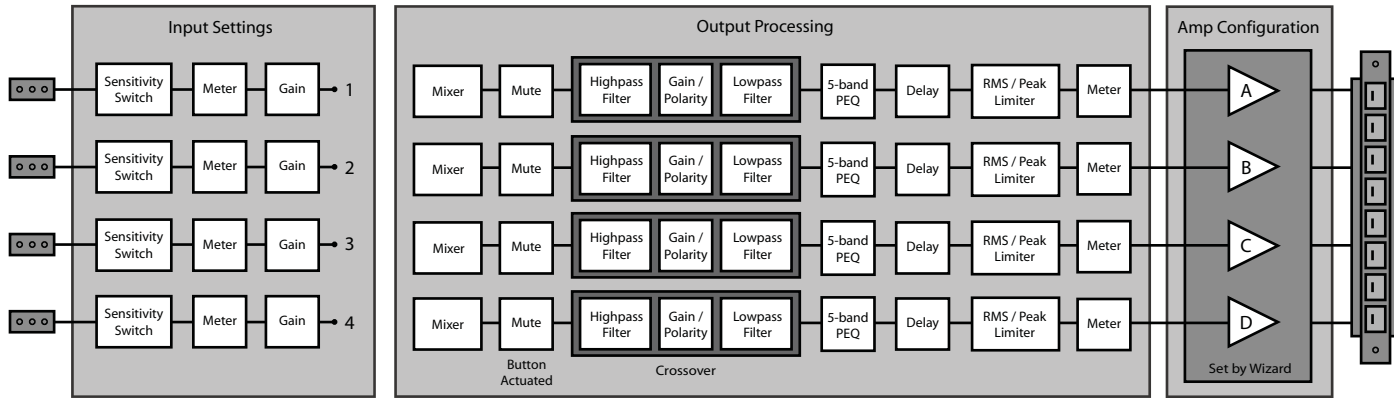

– Figure 10 –

## Amplifier Control

### Off Mode



- Rear power switch is off, the amplifier is not operable. The power switch is the AC Mains disconnect.
- The power button is not illuminated.
- Turn the power switch to on. The amplifier enters the Run Mode.
- The power button is illuminated blue.

### Run Mode



- From Standby or Mute All modes, press and release the power button on the front panel.
- The power button is illuminated blue.
- The amplifier is fully operable; audio can pass.

### Standby Mode



- From Mute All or Run modes, press and hold the power button on the front panel.
- The power button illuminates solid red.
- The amplifier is not operable; audio will not pass.

### Mute All Mode



- From the Run Mode, press and release the power button.
- The power button flashes red.
- The front panel and DSP functionality are fully operable. Any changes you make are saved and take effect in the Run Mode.

### Master Control Knob



- Scrolls up/down and right/left to select menu items and parameters
- Adjusts parameters

### ENTER Button



- Navigates into the menu structure
- Enters the edit mode for adjusting parameters
- Confirms the changes you make

### EXIT Button



- Navigates out of the menu structure and parameter selection.
- In the edit mode, pressing EXIT reverts the value back to its prior state, and exits the edit mode.

### HOME Button



- If you are on the Home screen, pressing HOME displays the alternate Home screen. Pressing HOME again returns you to the primary Home screen.
- If you are on a navigation screen, pressing HOME takes you to the Home screen.
- If you are on an edit screen, pressing HOME will confirm any value being edited and take you to the Home screen.

### GAIN Button



- Pressing the GAIN button from any screen takes you to the output gain screen for the most recently accessed output channel.
- Pressing GAIN again confirms the gain change and returns to the screen you were on when you pressed GAIN.

### SEL Buttons



- Use these buttons to navigate between input channels or output channels. For example, if you are adjusting output gain on channel A, pressing the channel B SEL button takes you to the gain adjustment for channel B.
- These buttons change both Input and Output selection at the same time. For example, if you select Output A then switch to an Input screen, you are on Input 1.
- The SEL buttons are active on the Home page, Main Menu, and any Input or Output screen.
- The SEL buttons illuminate blue for output channels, and amber for input channels.

# Menu Tree

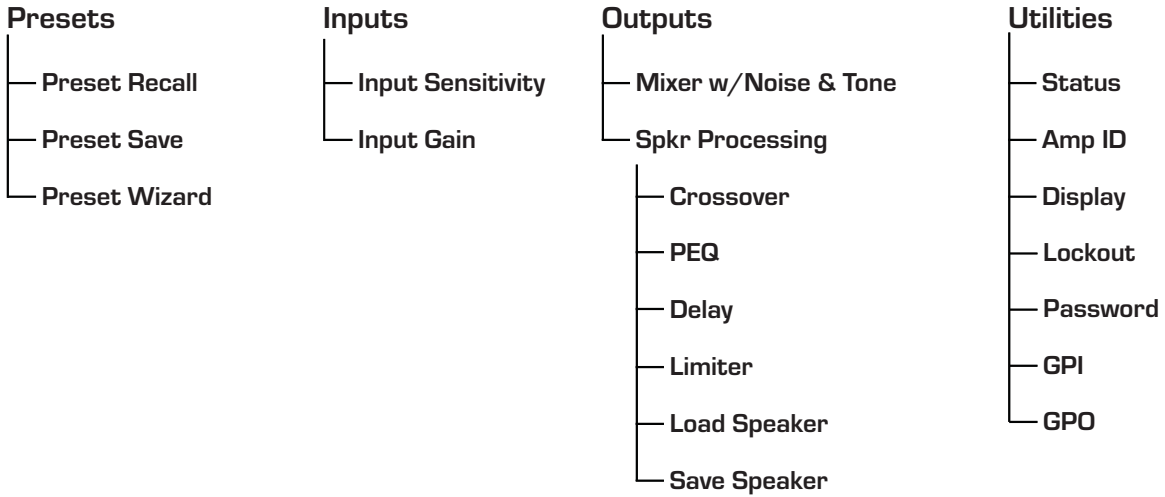

# Screen Types

## Informational

Informational screens, like the HOME screen, are designed to provide you with a good amount of useful information at a glance.

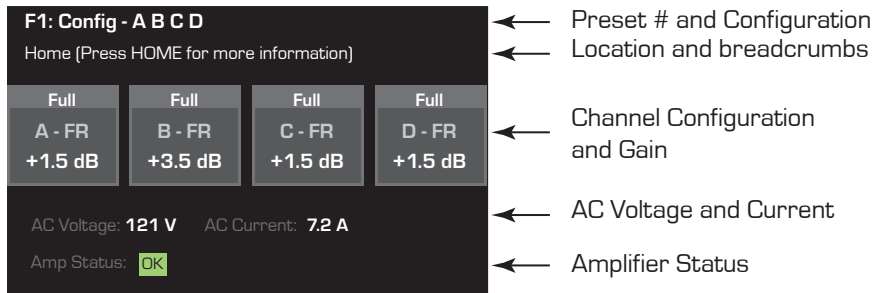

– Figure 11 –

## Navigational

Navigational screens provide the means to move around and select menu items. Use the Master Control knob, ENTER and EXIT buttons for navigation. This is an example of one type of navigational screen, there are others.

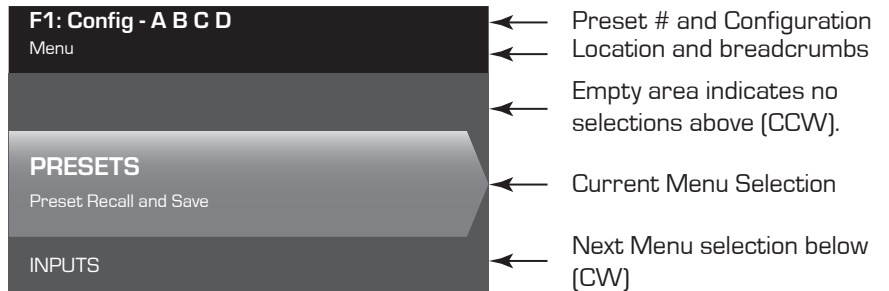

– Figure 12 –

## Parameter Editing

Parameter editing screens allow you to select, edit, and confirm changes for various system parameters. Use the ENTER button to edit and confirm changes to parameters. Use the Master Control knob to select parameter, and make adjustments. Use the EXIT button to exit the edit mode without saving changes.

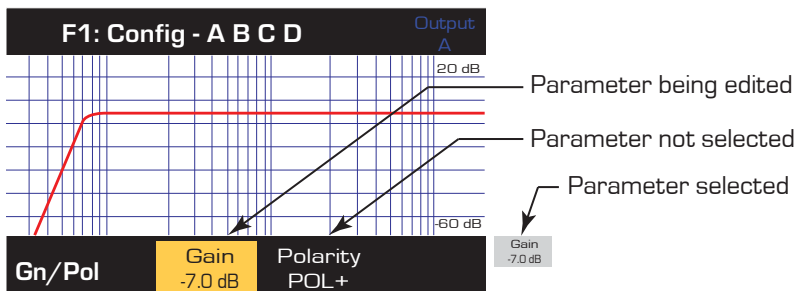

– Figure 13 –

# Presets

The DPA amplifiers are preset driven, so to get the most out of the amplifiers an understanding of how presets work is essential. A Preset, in the context of the DPA amplifiers, is a combination of amplifier configuration and DSP processing; as a preset is recalled it can change the output routing and wiring and/or any DSP processing.

## Preset Creation

A preset can be created in two ways, the first is to modify an existing preset, then save this as a new Preset; the second is to use the Preset Wizard to create a Preset from scratch.

## Preset Wizard

The Preset Wizard simplifies the preset creation process, and allows the user to create a preset from the ground up. The Wizard provides a mechanism for the user to select his desired power and load. Based on these selections, the best amplifier configuration is selected and the user is then allowed to select and assign loudspeakers to each output.

To start the Preset Wizard: HOME > PRESETS > PRESET WIZARD > ENTER

### STEP 1 – About the Preset Wizard

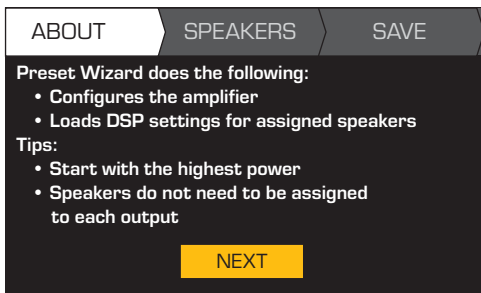

HOME > PRESETS > PRESET WIZARD > ENTER > ENTER

### STEP 2 – Adjust Impedance and Power

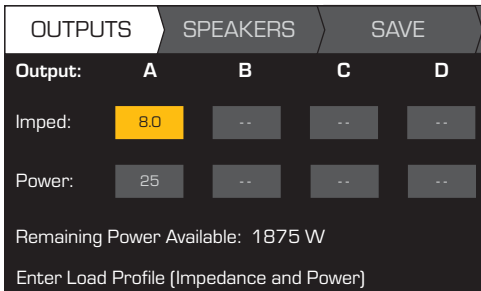

← Default = 8 Ω

← Default = min. for amp

Adjust Impedance  
Adjust Power



To confirm, press



Adjust Impedance based on the total loudspeaker load connected to the channel.

### Possible Output Mode Combinations using the Preset Wizard

A	B	C	D	A+B	C	D	A+B	C+D	A B + C D	A B C D
8.0	8.0	8.0	8.0	8.0	8.0	8.0	8.0	8.0	8.0	8.0
625	625	625	625	1250	625	625	1250	1250	2475	2500

Modes:

A B = Separate Channels

A+B = Bridge Mode

AB = Parallel Mode

– Figure 14 –

**STEP 3 – Select Output Channel for Speaker Assignment**

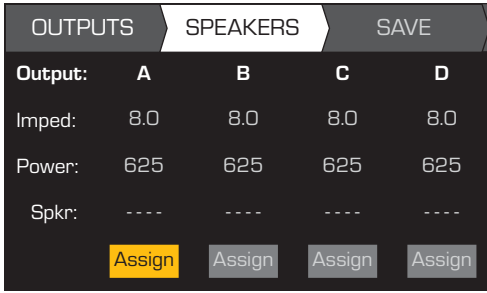

When you are finished setting the Impedance and Power for each output, continue to scroll to access the SPEAKERS tab.

Loudspeaker assignment is optional, you can assign a loudspeaker to one or more channels, or none at all.

Scroll to select the Output channel.



To Assign a loudspeaker, press



Continue to the next Step.

**STEP 4 – Select Speaker Type for Channel**

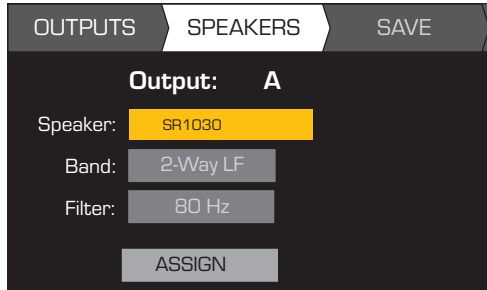

Band and Filter selections are based on the Speaker you select. You must select a loudspeaker before selecting Band and Filter.

To edit Speaker, press



Scroll to select a Speaker model



To confirm, press



Scroll to select (Band, Filter)



To edit, press



Turn to adjust parameter



To confirm, press



Scroll to select ASSIGN



To assign the speaker to the output channel, press



**STEP 5 – Save Wizard Preset**

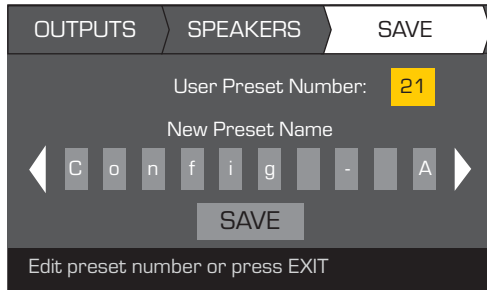

Scroll to the Save screen



To edit User Preset number, press



To name and save the preset, Complete steps 1 thru 3 under "To Save a New User Preset"

**STEP 6 – Name the Loudspeaker Profile**

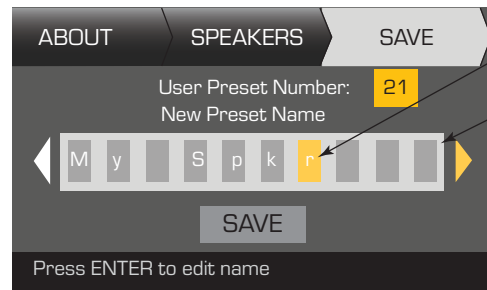

Indicates editing

To add Speaker Profile Name, press

Indicates "Speaker Profile Name" is selected

Scroll to desired letter position press

Turn to select desired character press

Up to 21 characters  
A-Z / a-z / 0-9 /  
\_ / - / space

When finished, scroll to SAVE press

## Saving Presets

Presets can be modified and saved using the Save Preset menu. You can start with a Factory Preset (F<n>: <name>), make modifications, then save it as a User Preset (U<n>: <name>). You cannot overwrite Factory Presets. There are two ways to save Presets, Overwrite an existing User Preset, or Save a new User Preset.

To Overwrite a User Preset, **HOME > PRESETS > PRESET SAVE > ENTER**

### Overwrite Preset



To save, press



To exit without saving, press



To confirm the save, press



To Save a New User Preset, **HOME > PRESETS > PRESET SAVE AS > ENTER**

### STEP 1 – Select and Edit Preset Number



To edit User Preset number, press



Scroll to desired number (1 thru 50)



To confirm User Preset number, press



### STEP 2 – Name the Preset

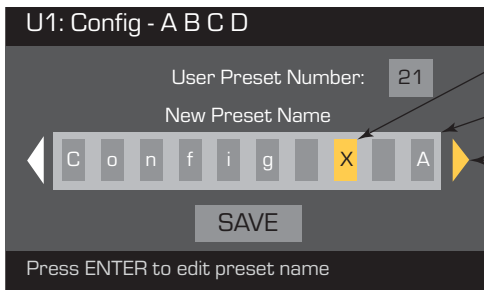

Indicates editing

Scroll to New Preset Name



Indicates New Preset Name selection

Press



Indicates more positions

Scroll to desired position



Press



Up to 21 characters, A - Z / a - z / 0 - 9 / \_ / - / space

### STEP 3 – Save Preset

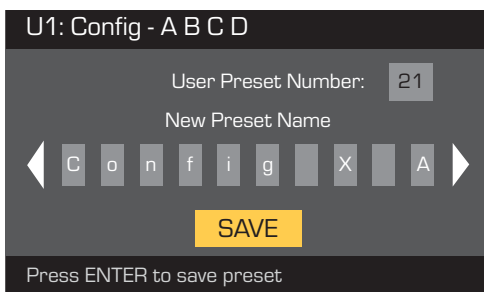

When you are finished naming, press



Scroll to SAVE



Press



To confirm Save, press





## Recalling Presets

Recalling a Preset changes the configuration of the amplifier. You can recall factory or user-defined presets. To Overwrite a User Preset,

**HOME > PRESETS > PRESET RECALL > ENTER**

### STEP 4 – Select Preset

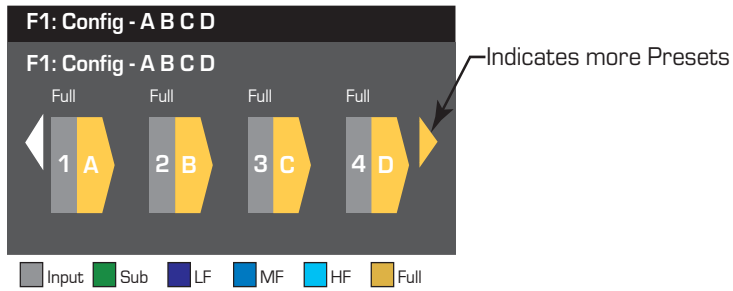

Scroll to desired Preset  
20 Factory, up to 50 User-defined



### STEP 5 – Confirm Selection

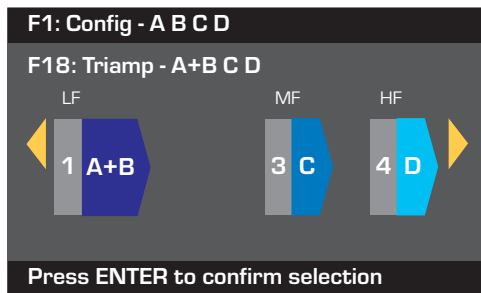

To select the Preset configuration, press



To Confirm the selection, press



Bottom message changes to: "Recalling Preset now..."  
You may hear relays clicking

## Utilities

The Utilities section provides the following amplifier information and functionality: Please refer to the DPA User Manual for complete details.

- STATUS
- ID
- Serial Number
- LOCKOUT
- PASSWORD
- GPIO



Mailing Address:

QSC Audio Products, LLC  
1675 MacArthur Boulevard  
Costa Mesa, CA 92626-1468 USA

Telephone Numbers:

Main Number: (714) 754-6175  
Sales & Marketing: (714) 957-7100 or toll free (USA only) (800) 854-4079  
Customer Service: (714) 957-7150 or toll free (USA only) (800) 772-2834

Facsimile Numbers:

Sales & Marketing FAX: (714) 754-6174  
Customer Service FAX: (714) 754-6173

World Wide Web:

[www.qsc.com](http://www.qsc.com)

E-mail:

[info@qsc.com](mailto:info@qsc.com)  
[service@qsc.com](mailto:service@qsc.com)  
[tech\\_support@qsc.com](mailto:tech_support@qsc.com)

If you would like a full copy of the DPA User manual, visit the QSC Audio Products website at [www.qsc.com](http://www.qsc.com), or contact Customer Service +1 714 957-7150 or toll free (USA only) (800) 772-2834 to receive a copy by mail.

Si desea obtener una copia completa del manual del usuario de la DPA, visite el sitio web de QSC Audio Products en [www.qsc.com](http://www.qsc.com), o póngase en contacto con el Servicio al Cliente al +1 714 957-7150 o sin costo (sólo en EE.UU.) al (800) 772-2834 para recibir una copia por correo.

Pour obtenir un exemplaire complet du manuel d'utilisation de la DPA, allez sur le site Web QSC Audio Products à [www.qsc.com](http://www.qsc.com) ou contactez le service clientèle au +1 714 957-7150 ou au (800) 772-2834 (numéro vert - USA seulement) pour recevoir un exemplaire par courrier.

Ein vollständiges Exemplar des Benutzerhandbuchs für die DPA finden Sie auf der QSC Audio Products-Website unter [www.qsc.com](http://www.qsc.com). Sie können sich unter +1 714 957-7150 oder unter der (nur in den USA) gebührenfreien Nummer +1 (800) 772-2834 auch an den Kundendienst wenden, um sich ein Exemplar zuschicken zu lassen.

如果您需要 DPA 产品用户手册的完整副本，请访问 QSC 音频产品网站 [www.qsc.com](http://www.qsc.com)，或致电客户服务部门 +1 714 957-7150，或拨打免费电话（仅限美国）(800) 772-2834 通过邮件获取副本。