

THIS DOCUMENT CONTAINS PROPRIETARY INFORMATION WHICH IS THE PROPERTY OF QSC, LLC. THAT MAY NOT BE DISCLOSED, REPRODUCED OR USED WITHOUT EXPRESS WRITTEN CONSENT FROM QSC, LLC.

REVISIONS			
REV	DESCRIPTION	BY	DATE
A	RELEASE FOR SALES AND MARKETING	ES	12-JUL-17

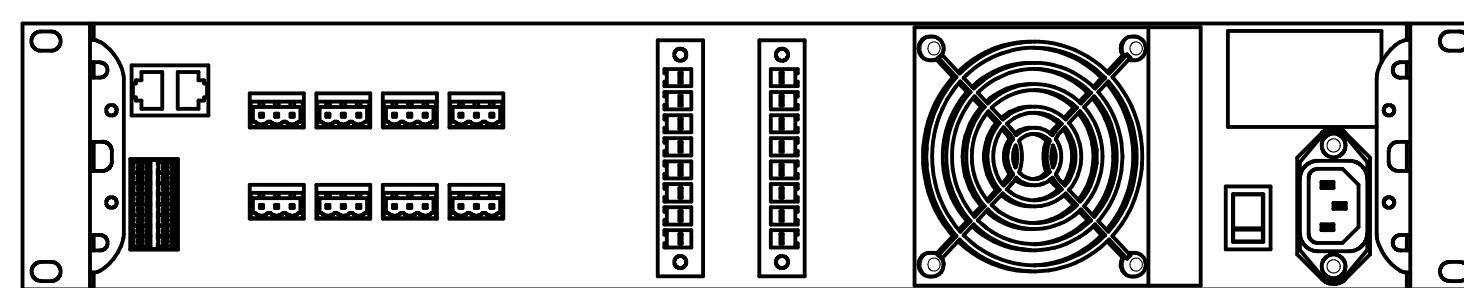
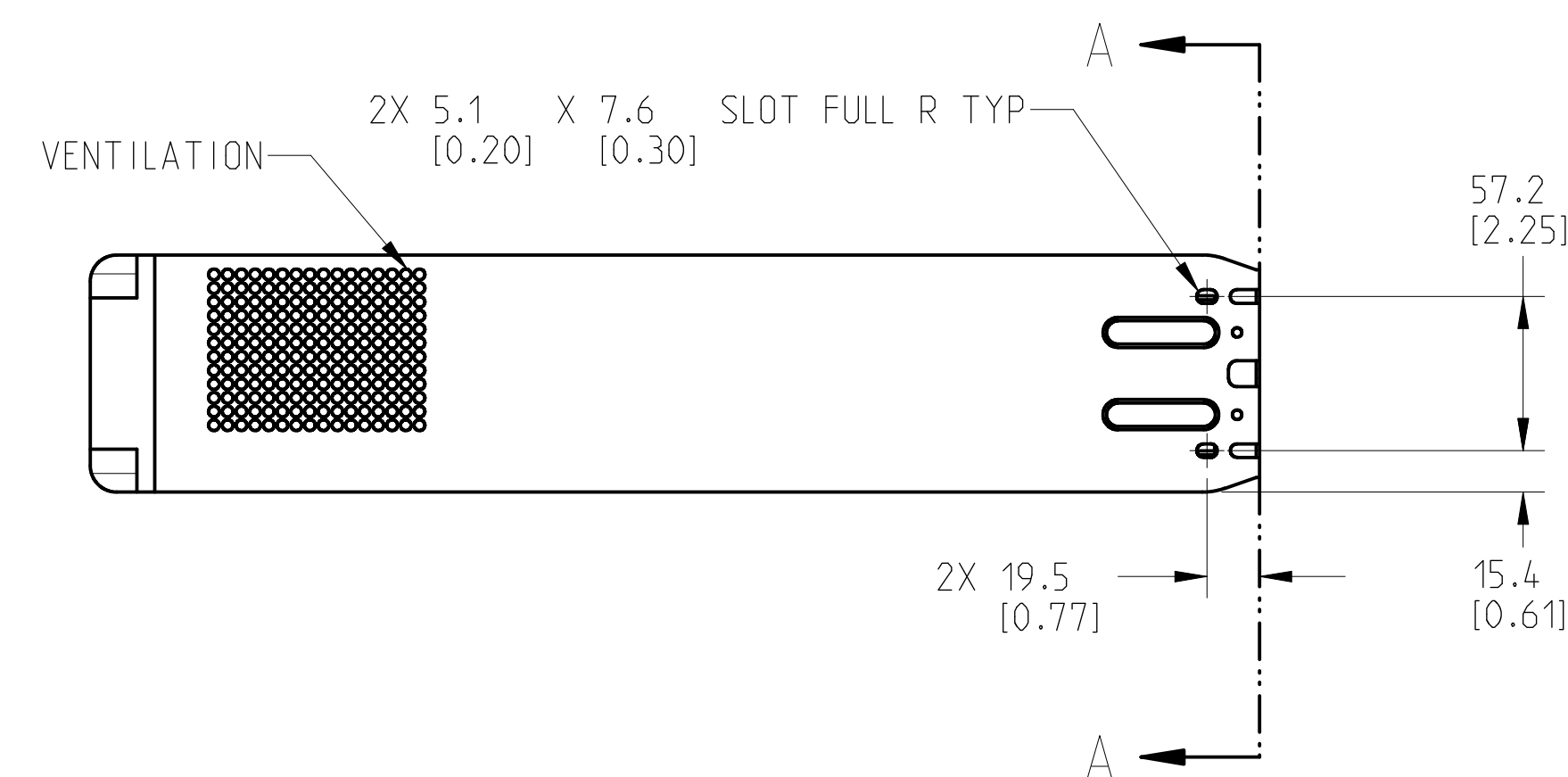
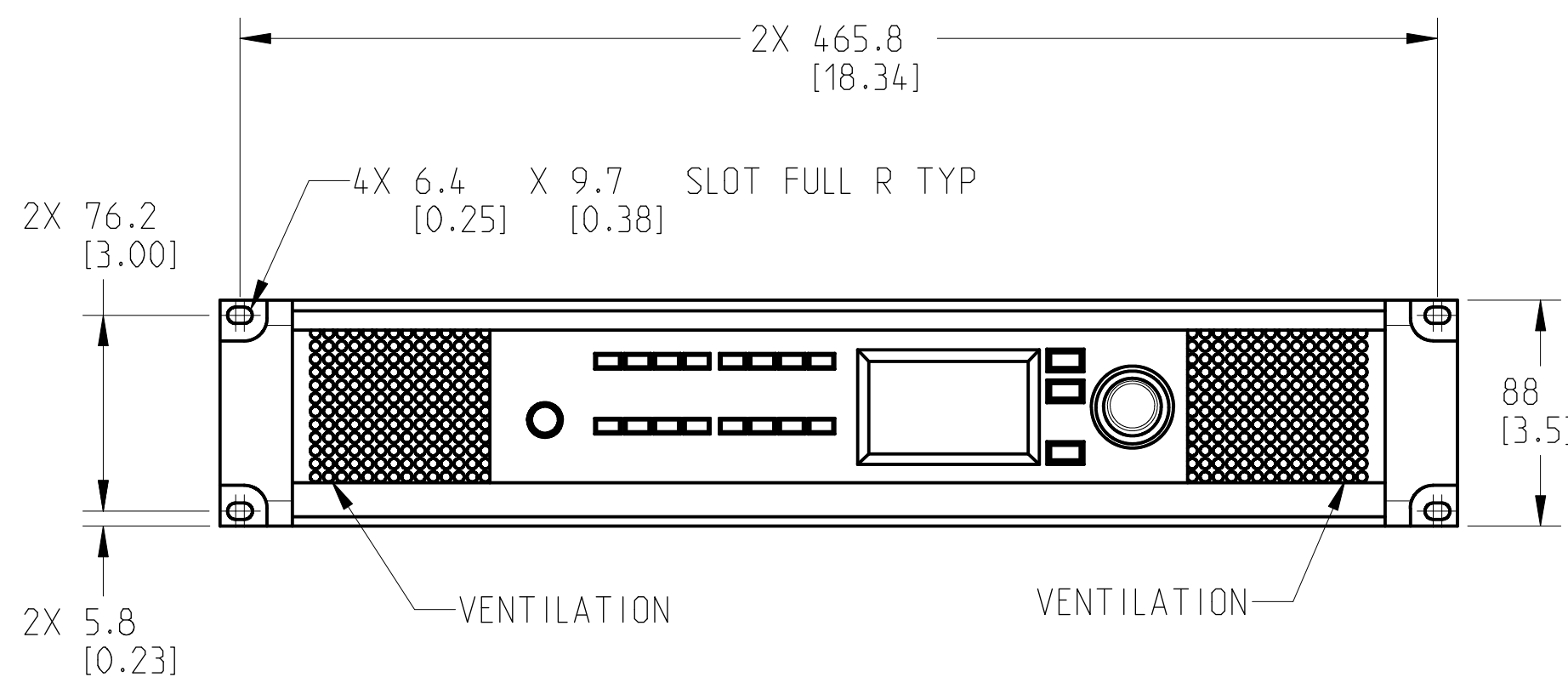
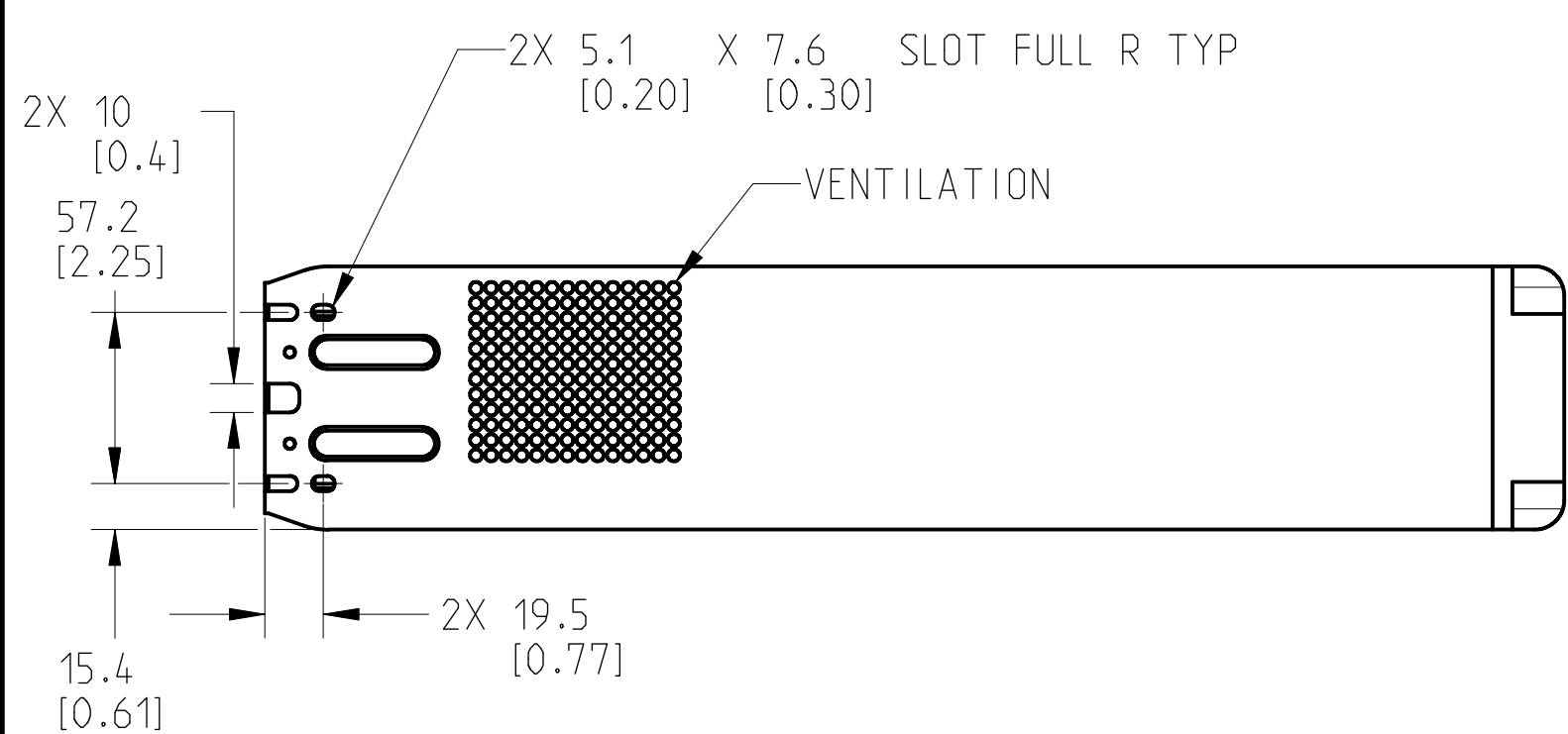
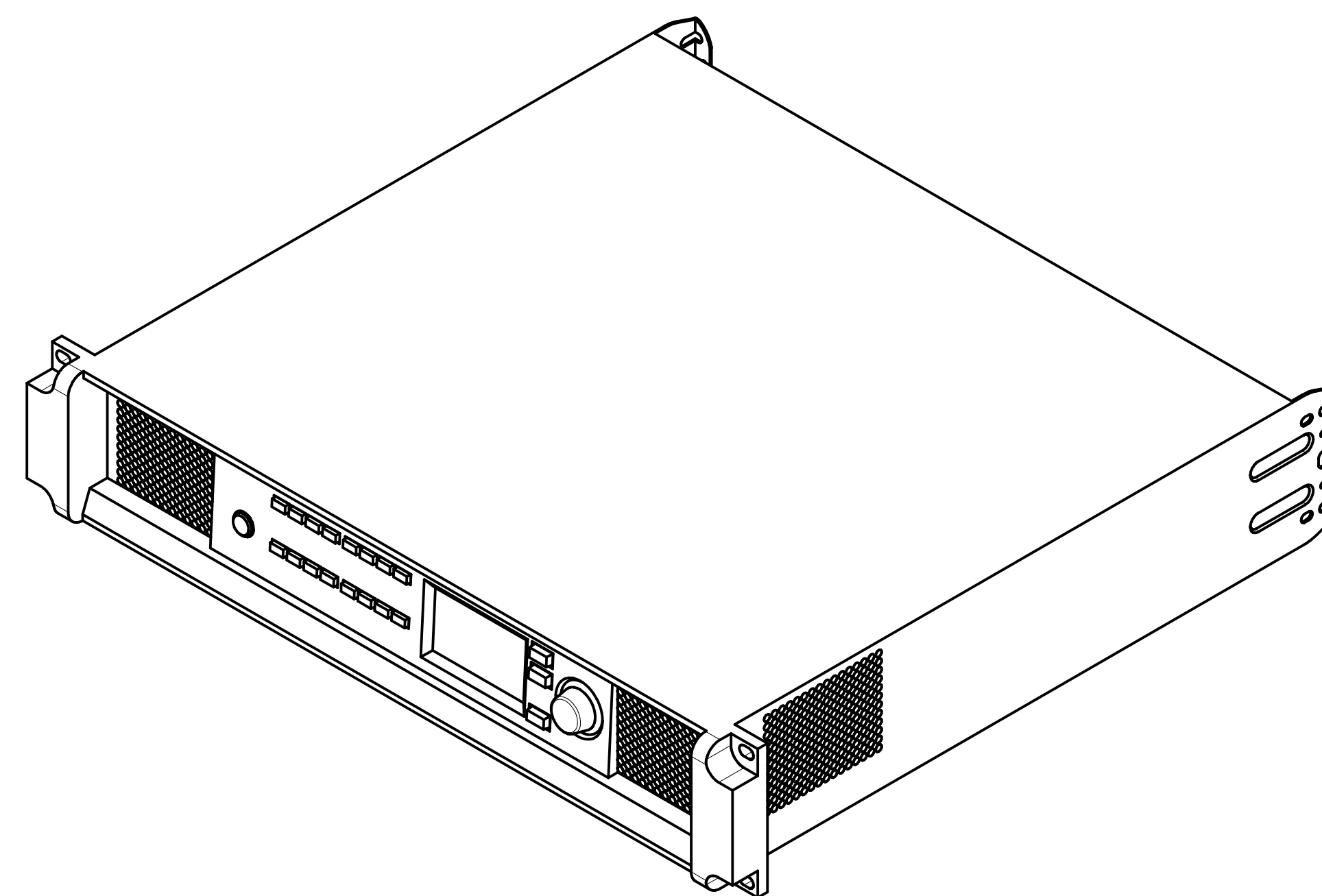
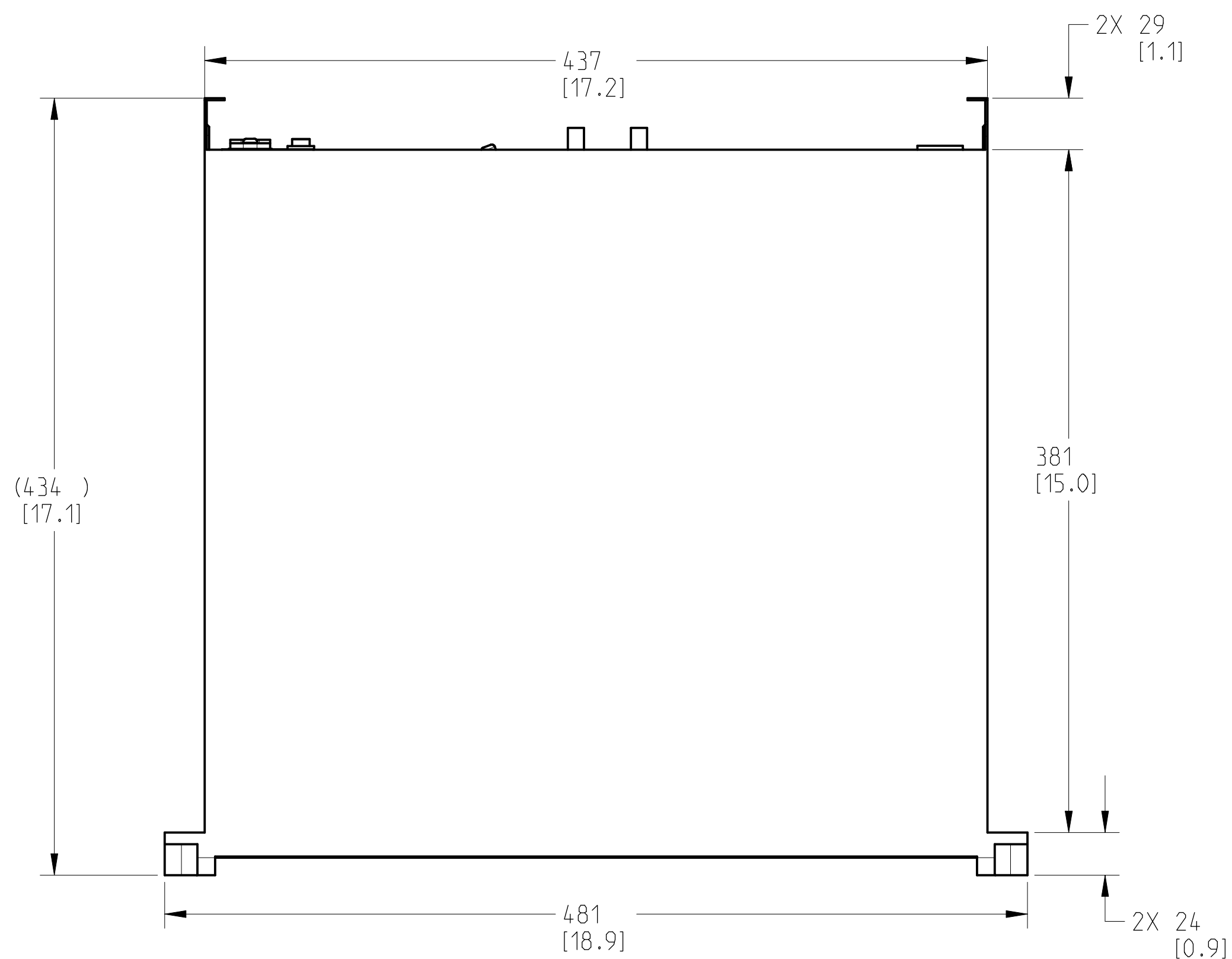

VIEW A-A  
REAR VIEW

3. DIMENSIONS ARE IN MILLIMETERS [INCH].
2. TOLERANCES (MM): X ± 3, ANGLES: ± 1°.
1. NET WEIGHT APPROXIMATELY 11.5 KG [25.5 LBS].

NOTES: UNLESS OTHERWISE SPECIFIED

UNLESS OTHERWISE SPECIFIED DIMENSIONS IN MILLIMETERS (IN) TOLERANCES ARE: DECIMALS DECIMALS ANGLES .X±.5(0.01) .XX±.25(0.01) ± 1/2 DECURR EDGES .25 (1.01) R MAX MATERIAL FINISH	DESIGNER ENG. SERVICES	QSC, LLC 1675 MACARTHUR BOULEVARD COSTA MESA, CA 92626	FINISHED, AMPLIFIER, DPA 8.8Q SERIES, 100-240V, E005	SIZE	CAGE CODE	DRAWING NO.	REV
	ENGINEER			D	00PW4	FS-220135-2D	A
	TECHNICAL DIRECTOR	SCALE: 0.400	DO NOT SCALE DRAWING	SHEET	1 OF 1		
	MANUFACTURING ENGINEER						
DRAWING INFO: FS-220135-2D.A.1							
MODEL INFO: FS-220135-3D.A.1							