

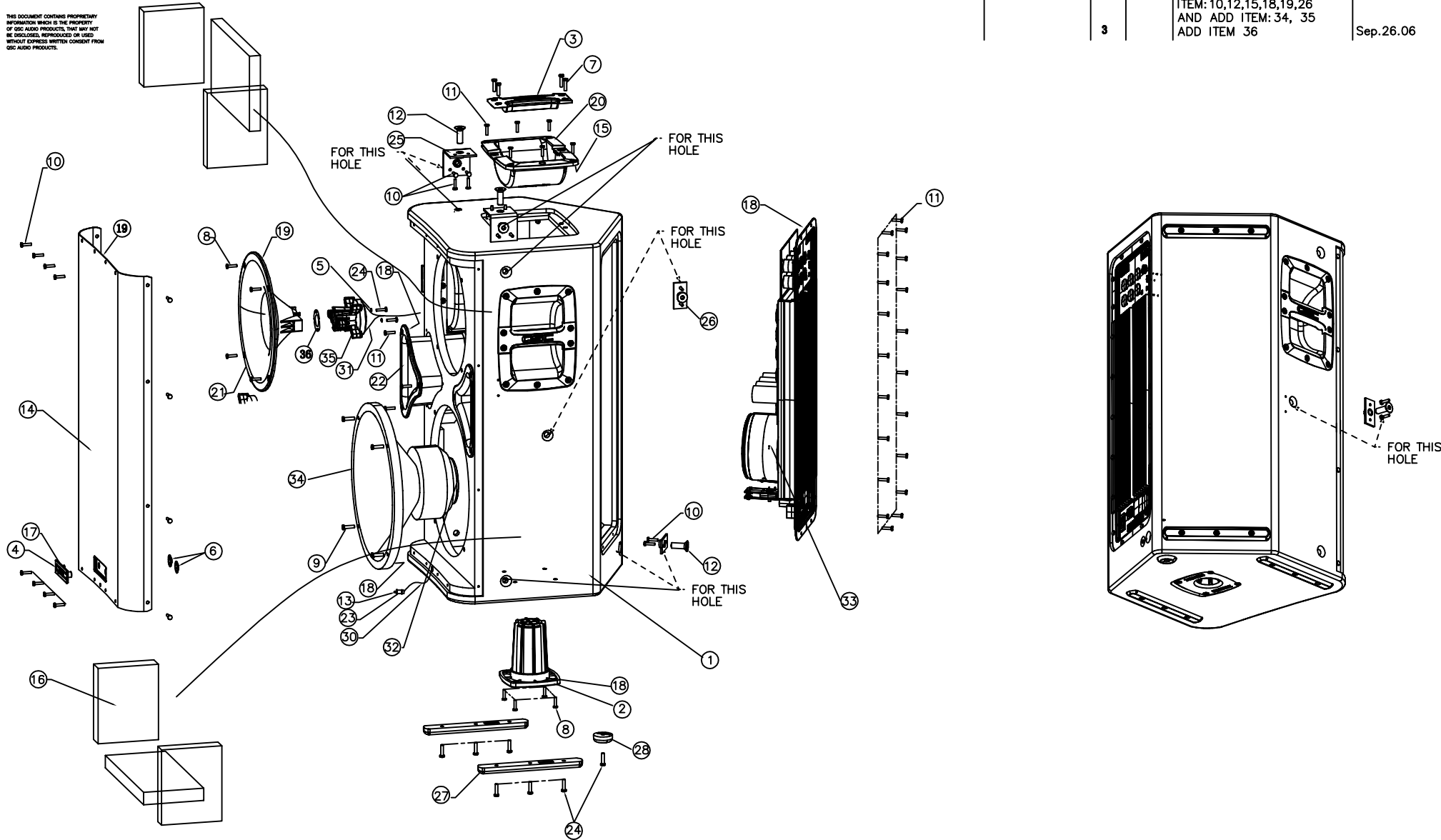

WORK TO DIMENSIONS. REMOVE ALL BURRS. ALL CASTINGS AND MOULDING TO BE FREE FROM SINKS AND BLEMISHES.

5		6		
GPE EN. NO.	REV	ZONE	DESCRIPTION	DATE
	1		DRAWING RELEASE	Aug.16.06
	2		UPDATE QTY. OF	Sep.20.06
	3		ITEM: 10,12,15,18,19,26 AND ADD ITEM: 34, 35 ADD ITEM 36	Sep.26.06

THIS DOCUMENT CONTAINS PROPRIETARY INFORMATION WHICH IS THE PROPERTY OF QSC AUDIO PRODUCTS. IT MAY NOT BE DISCLOSED, REPRODUCED OR USED WITHOUT EXPRESS WRITTEN CONSENT FROM QSC AUDIO PRODUCTS.



GEOMETRIC TOLERANCE & POSITIONAL TOLERANCE SHOULD BE IN ACCORDANCE WITH [GB/T 1184-1996]

**QSC** QSC AUDIO PRODUCTS, INC.  
1675 MACARTHUR BOULEVARD  
COSTA MESA, CA 92626

UNLESS OTHERWISE SPECIFIED : TOLERANCES ARE		MODEL	USAGE	MATERIAL:	SIGNATURE	DATE	SIGNATURE	DATE	TITLE: EXPLODED DRAWING FOR HPR122i				
1 decimal place	±0.1mm	31 - 120mm	±0.3mm	HPR122i	UNLESS SPECIFIED COMPLY WITH THE [RoHS]	DRAWN: Huisheng Wu	Sep.20.06	CHECKED:		PART NO.			
1 - 5mm	±0.1mm	121 - 315mm	±0.5mm	FINISH:	CHECKED:		CHECKED:		SCALE	SIZE	DRAWING NO.	REV	3
6 - 30mm	±0.2mm	OVER 315mm	±0.8mm	ALL DIMENSIONS ARE IN MM	DO NOT SCALE DRAWING	APPROVED:			NTS	A4	explod-hpr122i_Ver3	PAGE	1 OF 2

Item Number	Component Description	Component Item Number	Qty
1	ENCLOSURE,,HPR122i,,	SB-000055-GP	1
2	HPR SUB POLE MOUNT	CH-000570-GP	1
3	HANDLE BAR,,HPR122i,	CH-000525-GP	3
4	HPR122i LOGO,,,,	PL-000499-GP	1
5	Z/T WASHER,M5X0.8X10MM,WZ,,	NW-000110-GP	2
6	S/L WASHER,M9.7X22X0.5,,	NW-000105-GP	2
7	SCREW,M5X20MM,,BLACK,	SC-000155-GP	12
8	SCREW,PH,M5X35MM,BLACK,,	SC-000097-GP	8
9	SCREW,M5,HEXAGON-SOCKET,,	SC-000092-GP	4
10	SCREW,TRUSS HEAD,M4X16,JHC030-00,,	SC-000099-GP	34
11	SCREW WOOD,M4X20,BIND HEAD BZ,,	SC-000100-GP	44
12	MACHINE SCREW,M10*26,,BLK,	SC-000156-GP	9
13	LED,3MM,BLUE SP,SLR343BB T 225419 ROHM,,	QD-000312-GP	1
14	GRILLE,,HPR122i,	CH-000524-GP	1
15	GASKET,1000X10X2MM,EVA B,,	PL-000062-GP	7
16	ACOUSTIC WOOL,300*490*30,,	MS-000415-GP	6
17	FOAM STRIP,MP1,406.4X6X4,SP8296,,	PL-000065-GP	1
18	EVA GASKET,5X500,,,,	PL-000066-GP	9
19	GRILLE,GASKET,FOR QBASS,,	PL-000067-GP	2
20	HANDLE CUP,,,,,	PL-000501-GP	3
21	HORN, HPR122i,,,,,	SP-000106-GP	1
22	HPR122i PORT,,,,,	PL-000495-GP	2
23	LED HOLDER,FOR HPR,,,,	PL-000479-GP	1
24	SCREW,M5X25,PAN HEAD,DIA 8XH2.5,BLACK,	SC-000094-GP	15
25	ANGLE RIGGING PLATE,,,,	CH-000571-GP	2
26	FLAT RIGGING PLATE,,,,	CH-000572-GP	5
27	RAIL FOOT,,,,,	PL-000496-GP	4
28	ROUND FOOT,,,,,	PL-000498-GP	1
29	CABLE TIE,2.5X120MM,KFB101,,	PL-000075-GP	3
30	WIRE,BLACK&BLACK,26 AWG TWIN,,1080MM,UL2468	WC-000420-GP	1
31	UL1015,WIRE,16AWG,,450MM,	WC-000349-GP	1
32	UL1015,WIRE,16AWG,,550MM,	WC-000350-GP	1
33	AMP MODULE ASSY,,HPR122i,120V,FULL RANGE, 12" 2-WAY	WP-122001-00	1
34	WOOFER,12",PAPER,NEODYMIUM,CELESTION,T5488_GPE	SP-000107-GP	1
35	COMPRESSION DRIVER,1.4",ALUMINUM,NEODYMIUM,CELESTION,CDX1-1425,T5455_GPE	SP-000086-GP	1
36	GASKET,D32XD26.5X1MM,EVA BK,,	PL-000061-GP	1