

THIS DOCUMENT CONTAINS PROPRIETARY INFORMATION WHICH IS THE PROPERTY OF QSC AUDIO PRODUCTS. THAT MAY NOT BE DISCLOSED, REPRODUCED OR USED WITHOUT EXPRESS WRITTEN CONSENT FROM QSC AUDIO PRODUCTS.

REV	DESCRIPTION	EFF. DATE	CHK	APPROVED DATE
A	Production release per ECO xxxx	00/00/00		

RAVE 's-24' SERIES ANALOG MODELS COMBINED

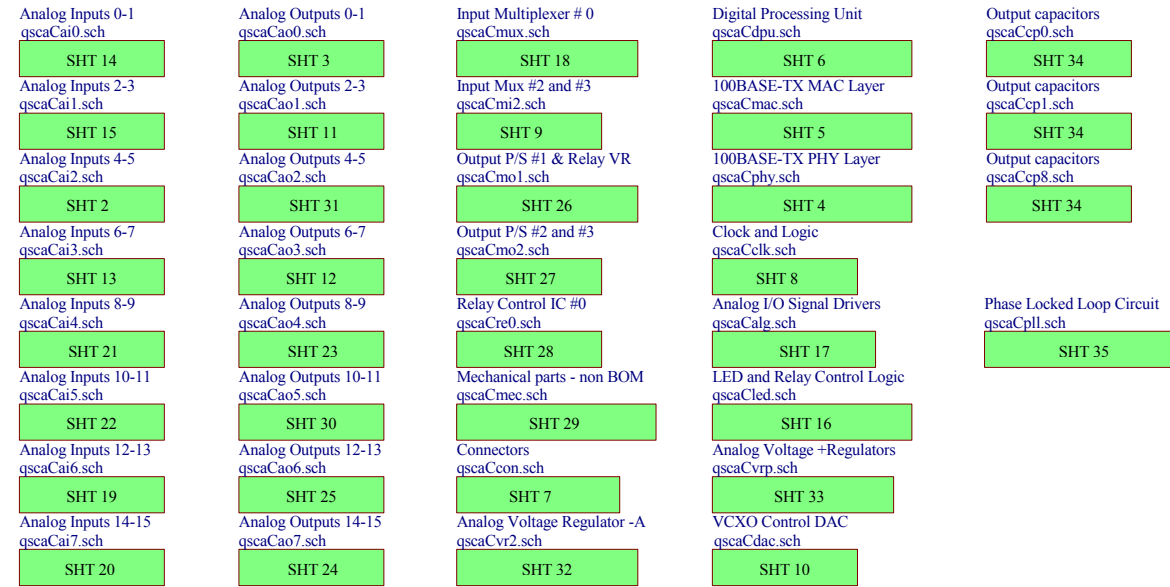

RAVE 160s-24 USE THE FOLLOWING SHEETS

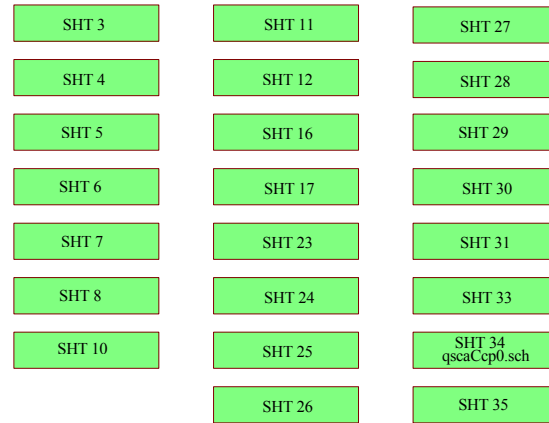

RAVE 161s-24 USE THE FOLLOWING SHEETS

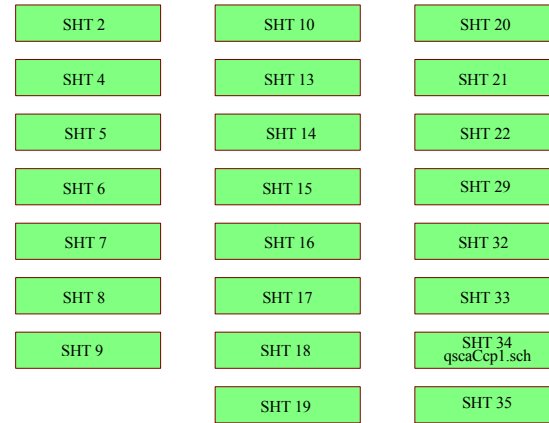

RAVE 188s-24 USE THE FOLLOWING SHEETS

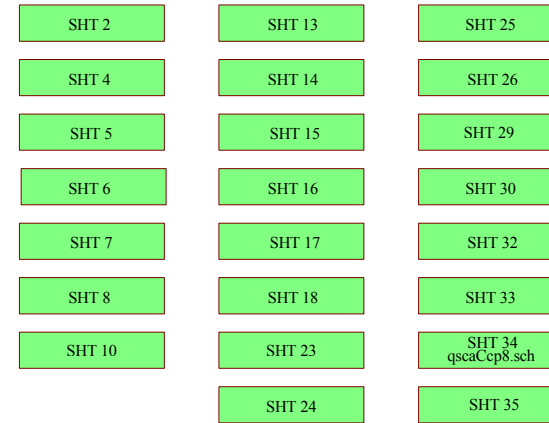

QSC AUDIO PRODUCTS, INC. 1675 MACARTHUR BLVD. COSTA MESA, CA 92626

Title: **RAVE Analog Block Diagram**

Size: **B** Number: **SH-000864-00** Rev **A**

File: C:\DATA\SCH\RAVE\Analog\Working\RAVE_beta2\864A\all\864A_all.DDB - Documents\864r\Abik.sch

Date: 11-Jan-2002 Eng: DARRYL HOCH Sheet 1 of 35

THIS DOCUMENT CONTAINS PROPRIETARY INFORMATION WHICH IS THE PROPERTY OF QSC AUDIO PRODUCTS. THAT MAY NOT BE DISCLOSED, REPRODUCED OR USED WITHOUT EXPRESS WRITTEN CONSENT FROM QSC AUDIO PRODUCTS.

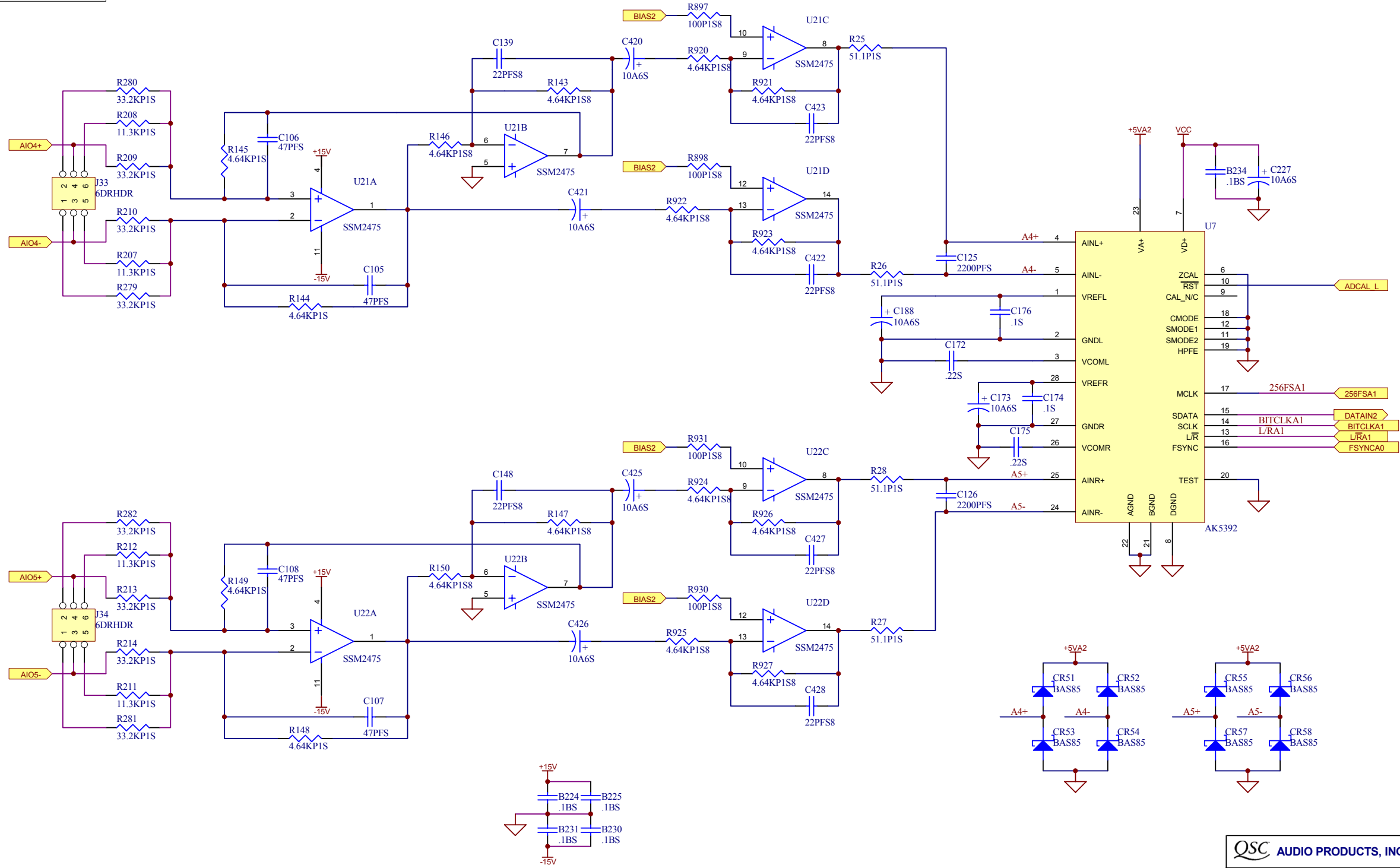

QSC AUDIO PRODUCTS, INC. 1675 MACARTHUR BLVD. COSTA MESA, CA 92626

Title: **RAVE Analog Inputs # 4-5**

Size: **B** Number: **SH-000864-00** Rev: **A**

File: C:\DATA\SCH\RAVE\Analog\Working\RAVE_beta2\864A\all\864A_all.DDB - Documents\qspa\Cal2.sch

Date: 11-Jan-2002 Eng: DARRYL HOCH Sheet 2 of 35

THIS DOCUMENT CONTAINS PROPRIETARY INFORMATION WHICH IS THE PROPERTY OF QSC AUDIO PRODUCTS. THAT MAY NOT BE DISCLOSED, REPRODUCED OR USED WITHOUT EXPRESS WRITTEN CONSENT FROM QSC AUDIO PRODUCTS.

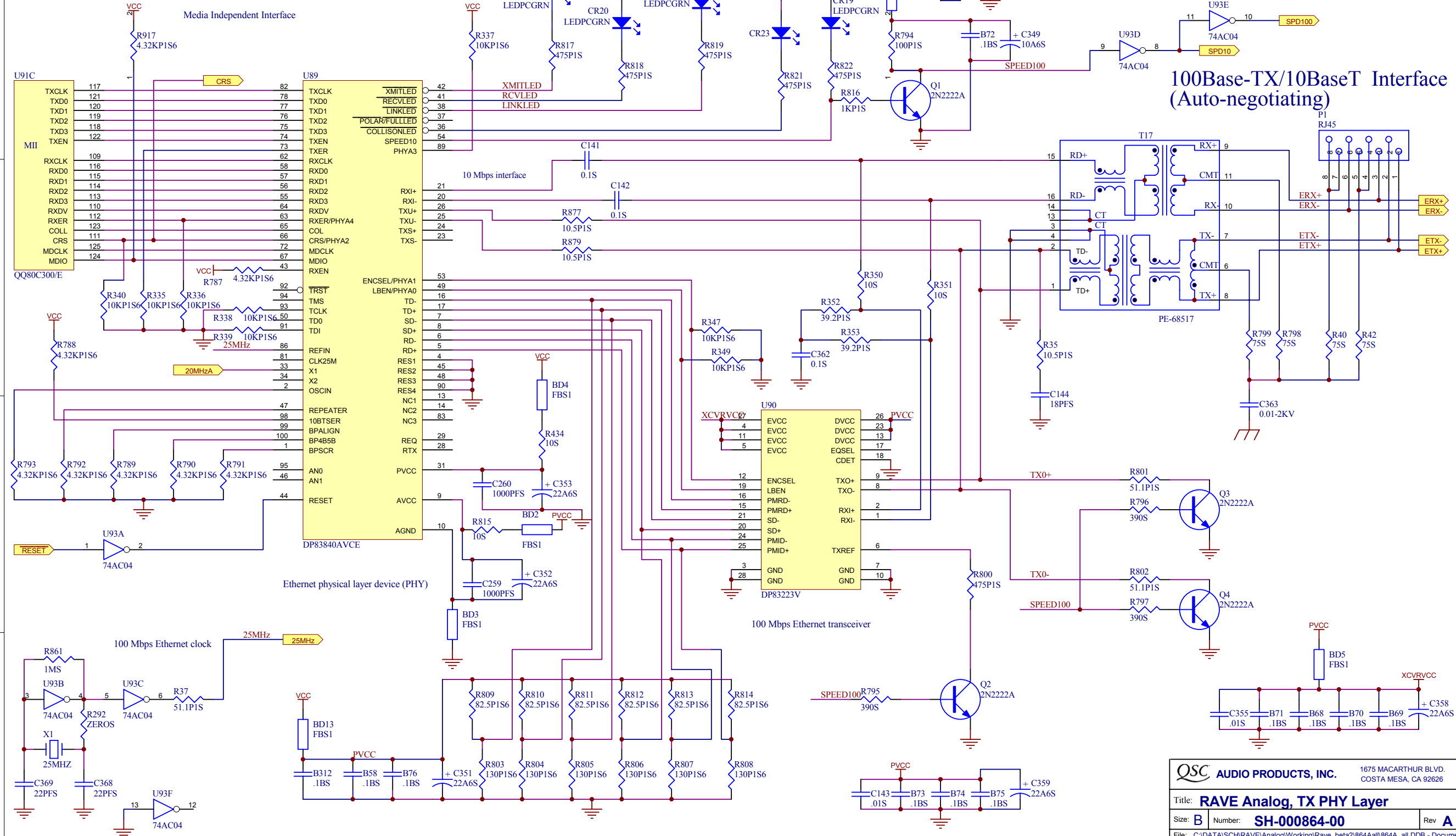

100Base-TX/10BaseT Interface (Auto-negotiating)

QSC AUDIO PRODUCTS, INC. 1675 MACARTHUR BLVD. COSTA MESA, CA 92626

Title: **RAVE Analog, TX PHY Layer**

Size: **B** Number: **SH-000864-00** Rev: **A**

File: C:\DATA\SCH\RAVE\Analog\Working\RAVE_beta2\864\Aall\864A_all.DDB - Documents\qsc\Cphy.sch

Date: 11-Jan-2002 Eng: DARRYL HOCH Sheet 4 of 35

THIS DOCUMENT CONTAINS PROPRIETARY INFORMATION WHICH IS THE PROPERTY OF QSC AUDIO PRODUCTS. THAT MAY NOT BE DISCLOSED, REPRODUCED OR USED WITHOUT EXPRESS WRITTEN CONSENT FROM QSC AUDIO PRODUCTS.

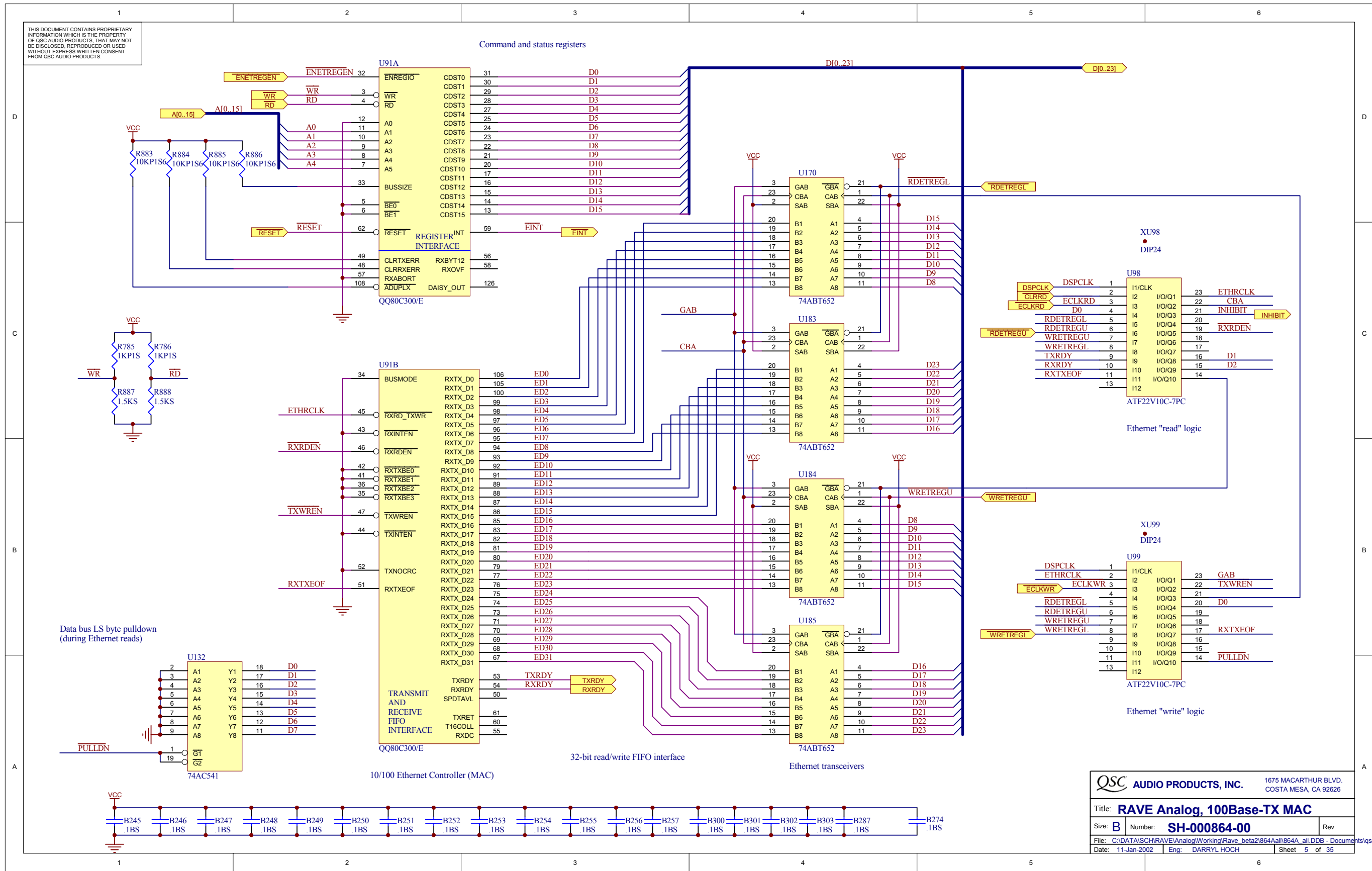

QSC AUDIO PRODUCTS, INC. 1675 MACARTHUR BLVD. COSTA MESA, CA 92626

Title: **RAVE Analog, 100Base-TX MAC**

Size: **B** Number: **SH-000864-00** Rev: _____

File: C:\DATA\SH\RAVE\Analog\Working\RAVE_beta2\864A\all\864A_all.DDB - Documents\qspaCmac.sch

Date: 11-Jan-2002 Eng: DARRYL HOCH Sheet 5 of 35

THIS DOCUMENT CONTAINS PROPRIETARY INFORMATION WHICH IS THE PROPERTY OF QSC AUDIO PRODUCTS. THAT MAY NOT BE DISCLOSED, REPRODUCED OR USED WITHOUT EXPRESS WRITTEN CONSENT FROM QSC AUDIO PRODUCTS.

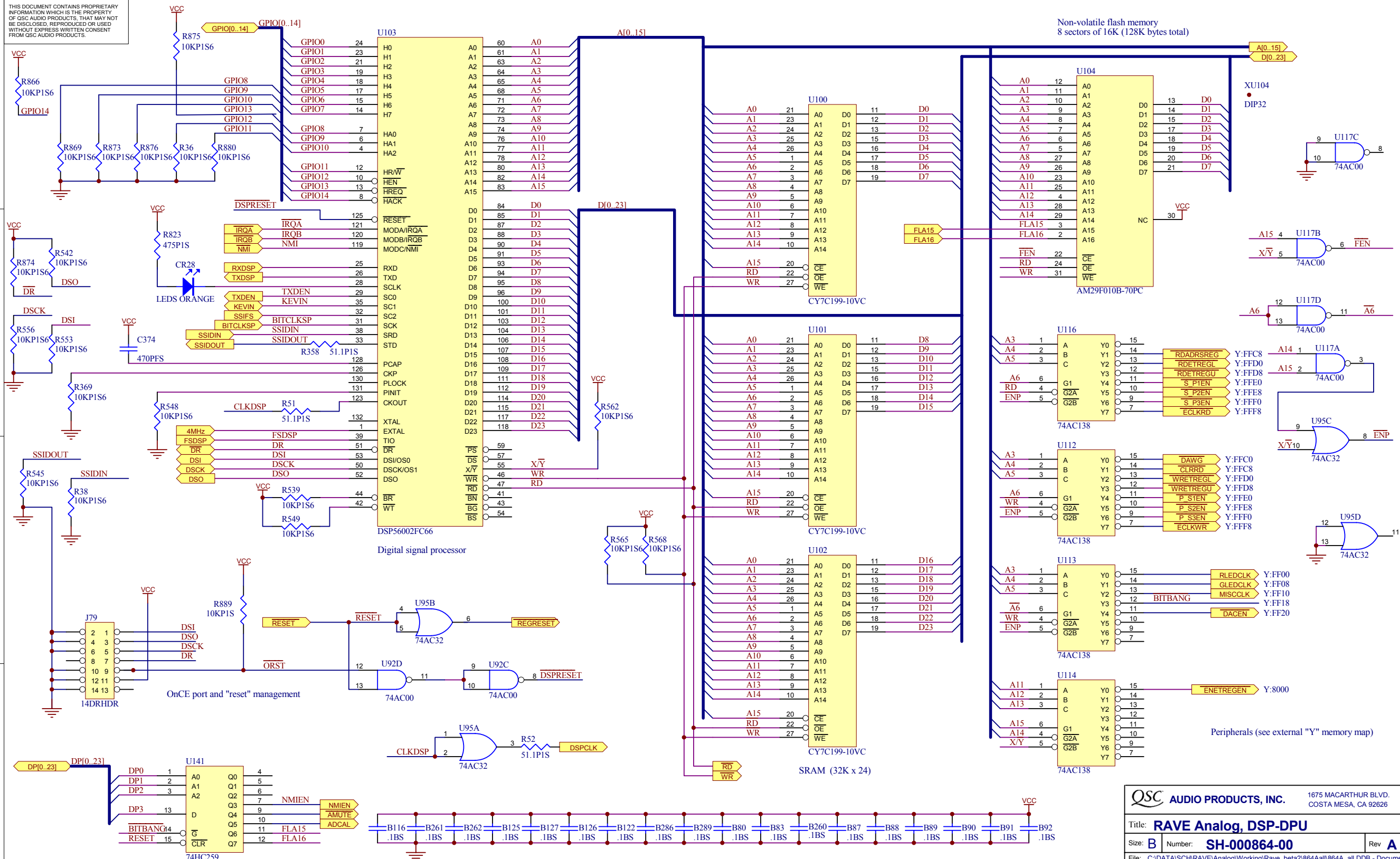

THIS DOCUMENT CONTAINS PROPRIETARY INFORMATION WHICH IS THE PROPERTY OF QSC AUDIO PRODUCTS. THAT MAY NOT BE DISCLOSED, REPRODUCED OR USED WITHOUT EXPRESS WRITTEN CONSENT FROM QSC AUDIO PRODUCTS.

Audio Phoenix connectors and LP filters

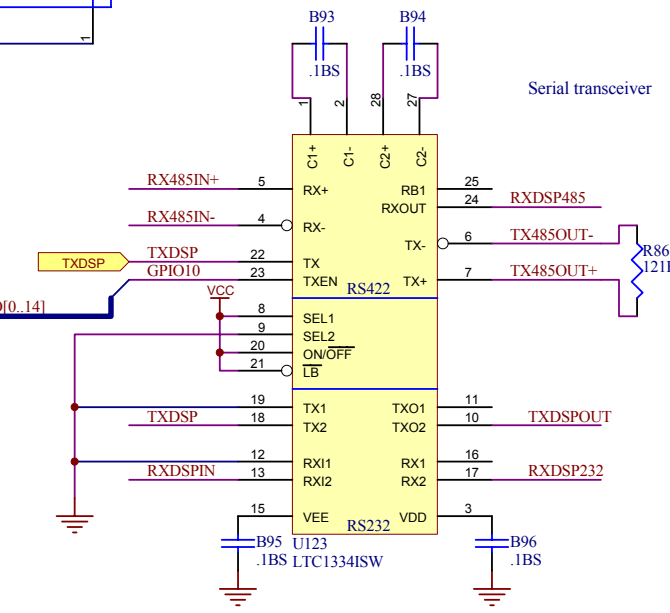
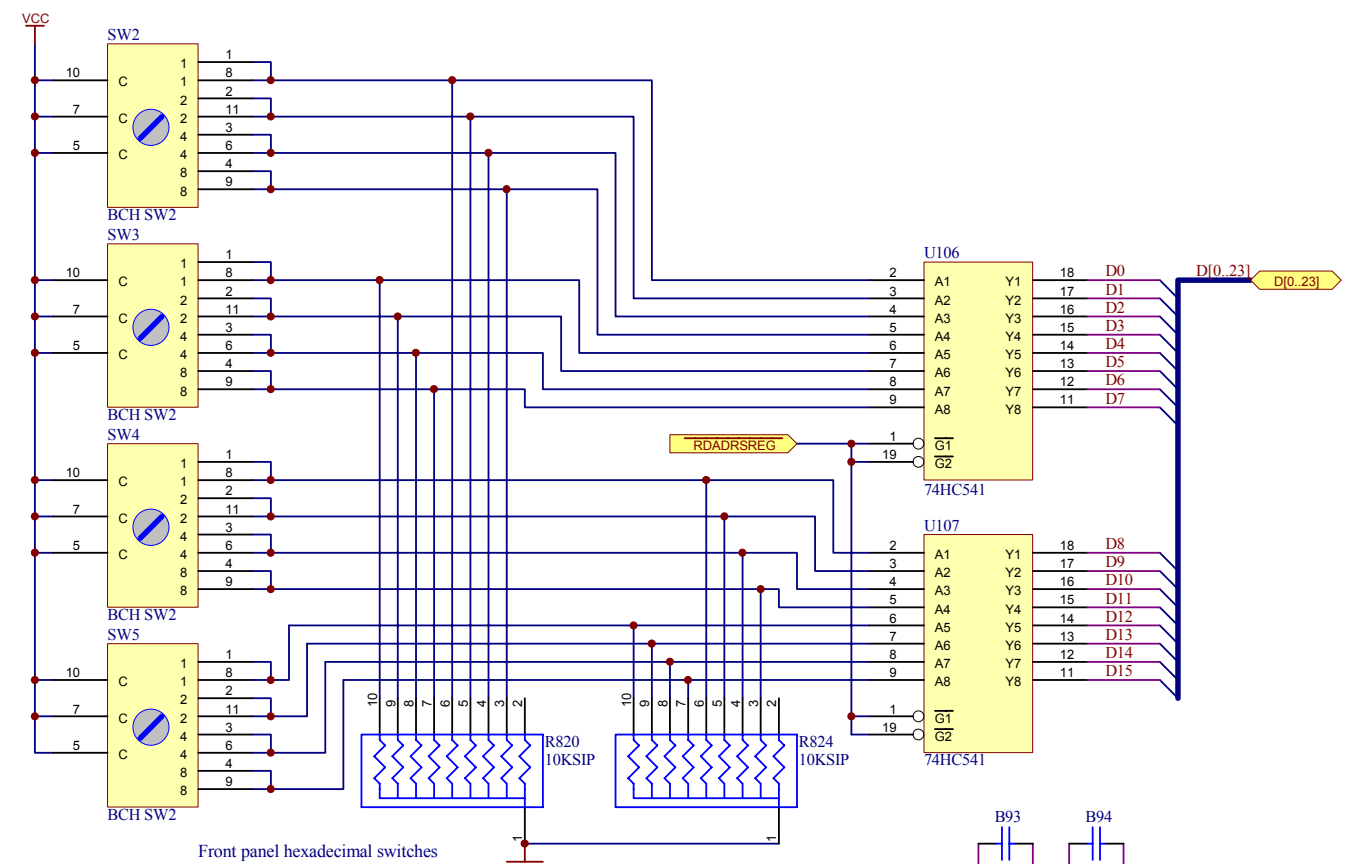
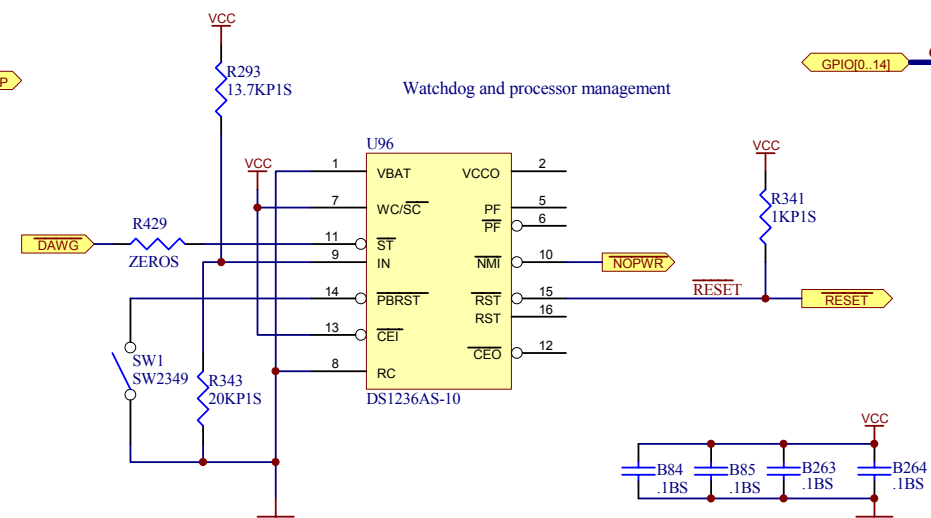
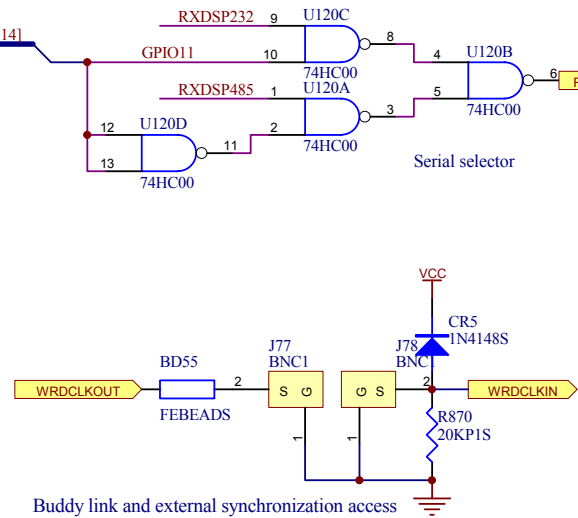
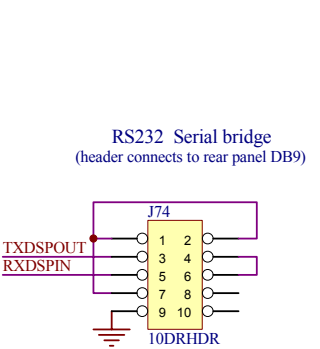
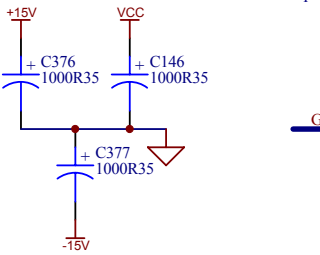
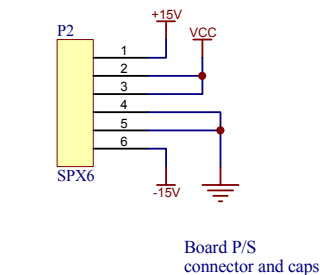
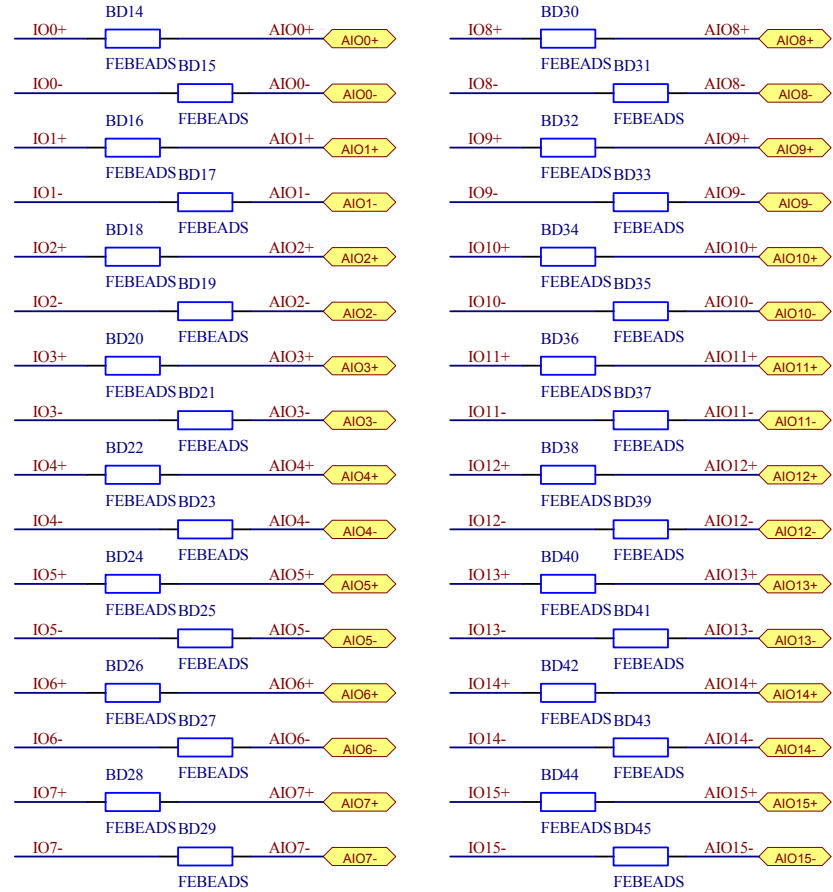
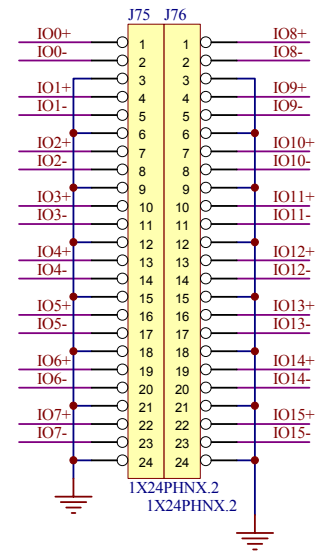

QSC AUDIO PRODUCTS, INC. 1675 MACARTHUR BLVD. COSTA MESA, CA 92626

Title: **RAVE Analog, Connectors**

Size: **B** Number: **SH-000864-00** Rev: **A**

File: C:\DATA\SH\RAVE\Analog\Working\RAVE_beta2\864\Aall\864A_all.DDB - Documents\qspa\Coon.qsp

Date: 11-Jan-2002 Eng: DARRYL HOCH Sheet 7 of 35

THIS DOCUMENT CONTAINS PROPRIETARY INFORMATION WHICH IS THE PROPERTY OF QSC AUDIO PRODUCTS. THAT MAY NOT BE DISCLOSED, REPRODUCED OR USED WITHOUT EXPRESS WRITTEN CONSENT FROM QSC AUDIO PRODUCTS.

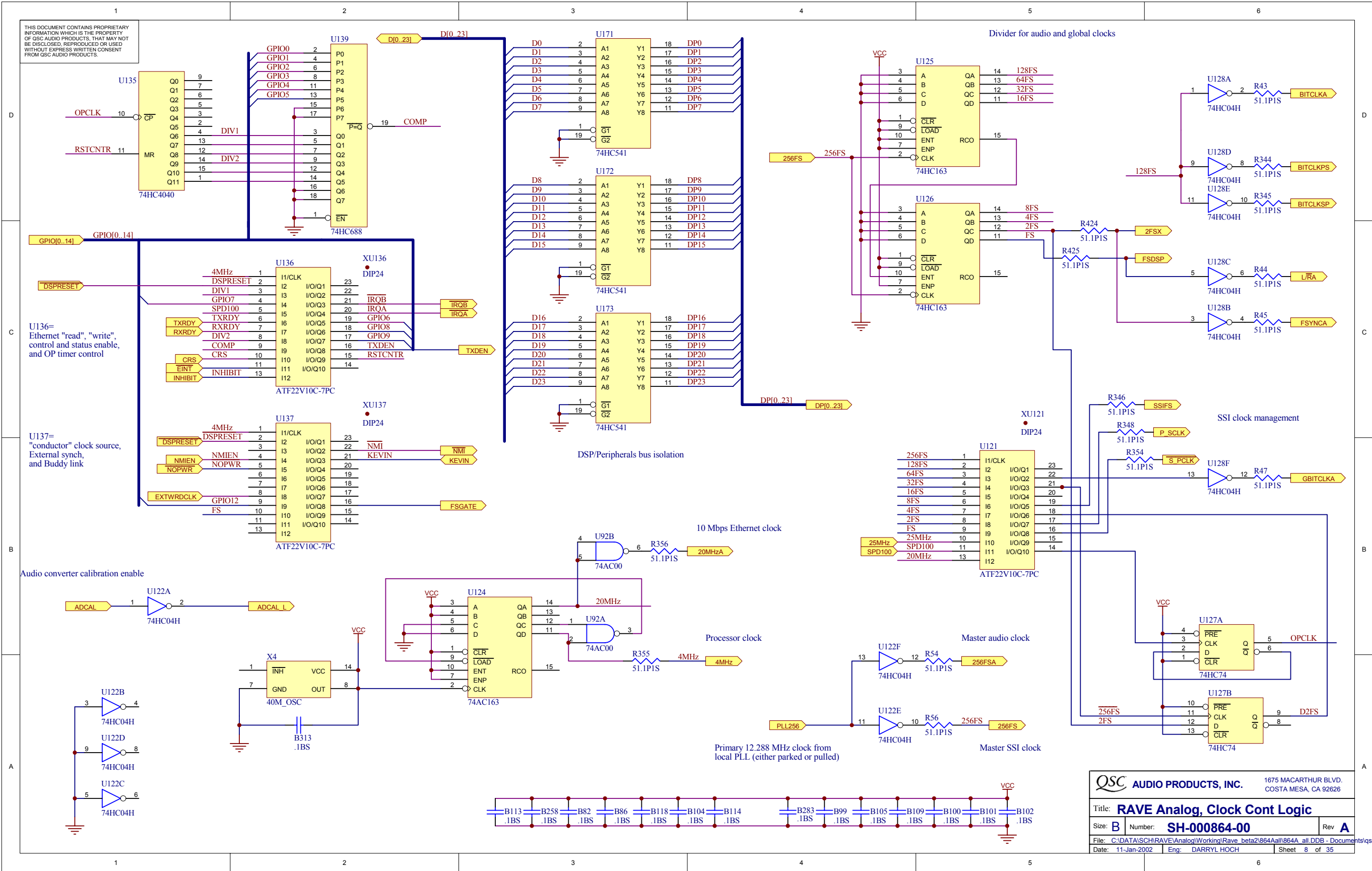

QSC AUDIO PRODUCTS, INC. 1675 MACARTHUR BLVD. COSTA MESA, CA 92626

Title: **RAVE Analog, Clock Cont Logic**

Size: **B** Number: **SH-000864-00** Rev: **A**

File: C:\DATA\SCH\RAVE\Analog\Working\RAVE_beta2\864A\all\864A_all.DDB - Documents\qspaCclk.sch

Date: 11-Jan-2002 Eng: DARRYL HOCH Sheet 8 of 35

THIS DOCUMENT CONTAINS PROPRIETARY INFORMATION WHICH IS THE PROPERTY OF QSC AUDIO PRODUCTS. THAT MAY NOT BE DISCLOSED, REPRODUCED OR USED WITHOUT EXPRESS WRITTEN CONSENT FROM QSC AUDIO PRODUCTS.

PLL DAC, provides controll voltage for VCXO

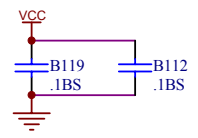
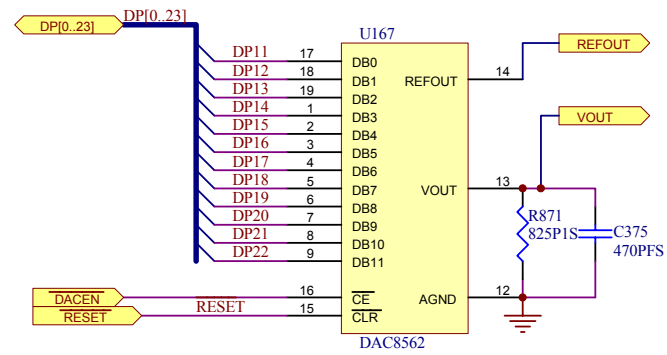

THIS DOCUMENT CONTAINS PROPRIETARY INFORMATION WHICH IS THE PROPERTY OF QSC AUDIO PRODUCTS. THAT MAY NOT BE DISCLOSED, REPRODUCED OR USED WITHOUT EXPRESS WRITTEN CONSENT FROM QSC AUDIO PRODUCTS.

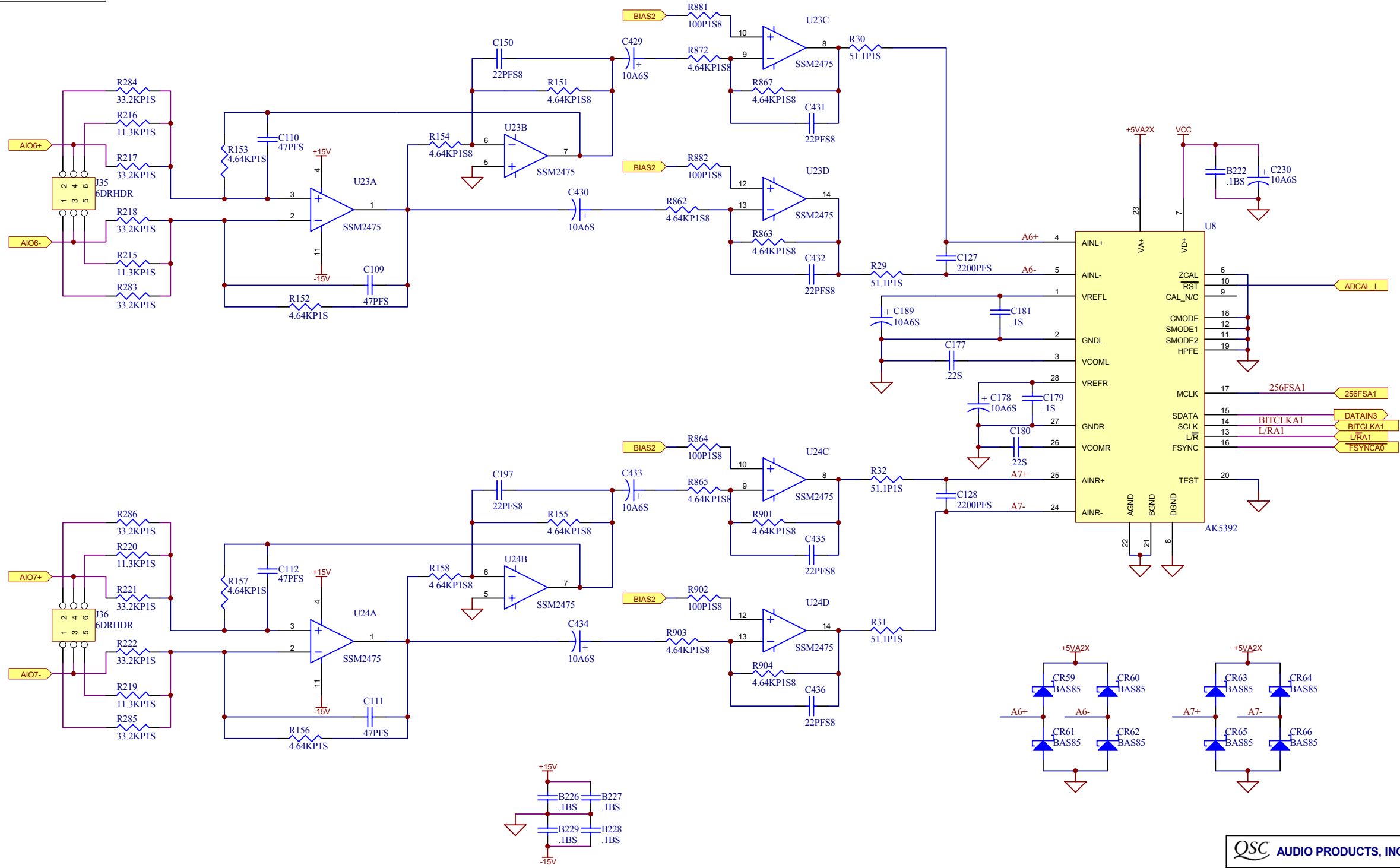

QSC AUDIO PRODUCTS, INC. 1675 MACARTHUR BLVD. COSTA MESA, CA 92626

Title: **RAVE Analog Inputs # 6-7**

Size: **B** Number: **SH-000864-00** Rev: **A**

File: C:\DATA\SCH\RAVE\Analog\Working\RAVE_beta2\864A\all\864A_all.DDB - Documents\qspa\Cal3.sch

Date: 11-Jan-2002 Eng: DARRYL HOCH Sheet 13 of 35

THIS DOCUMENT CONTAINS PROPRIETARY INFORMATION WHICH IS THE PROPERTY OF QSC AUDIO PRODUCTS. THAT MAY NOT BE DISCLOSED, REPRODUCED OR USED WITHOUT EXPRESS WRITTEN CONSENT FROM QSC AUDIO PRODUCTS.

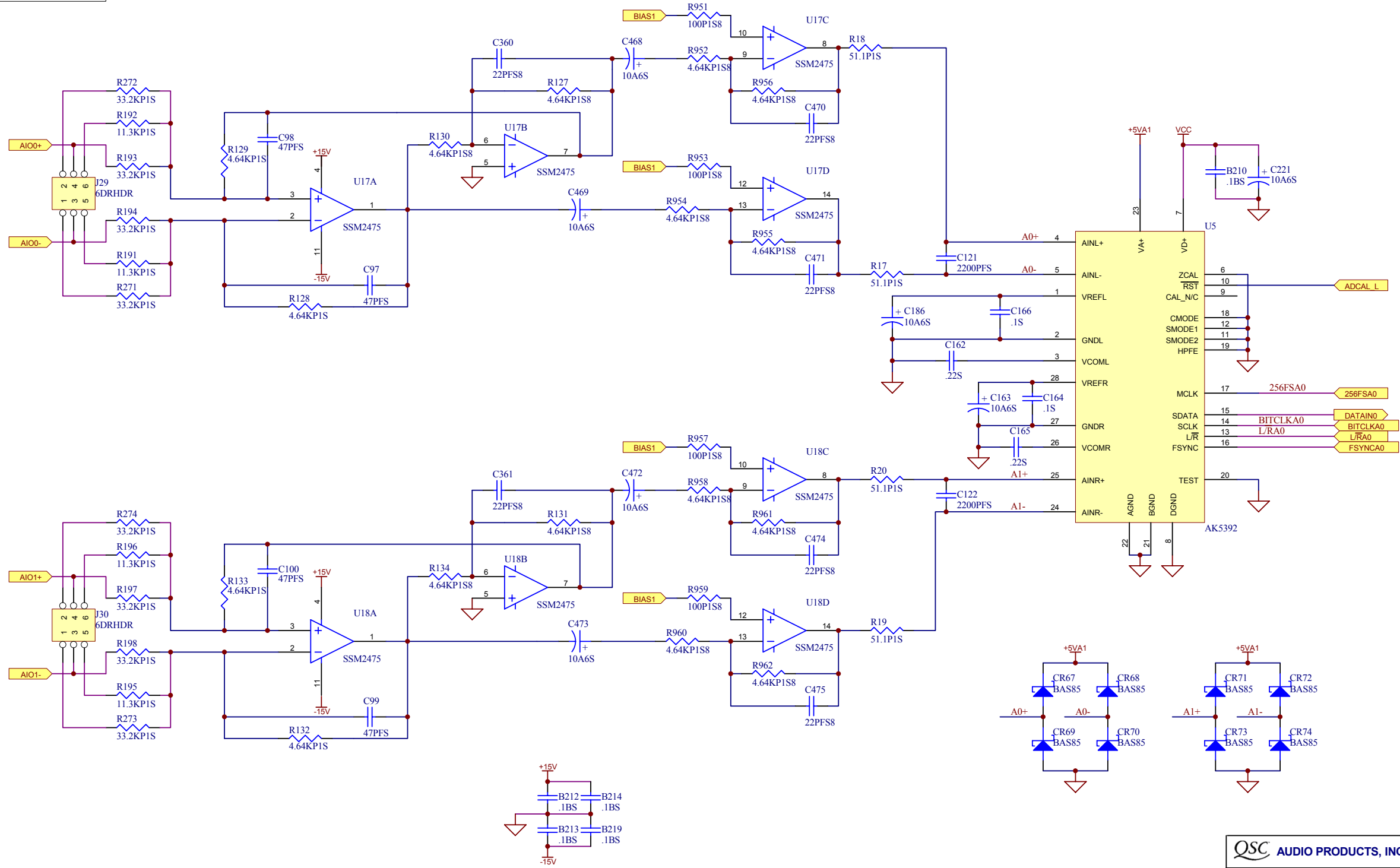

QSC AUDIO PRODUCTS, INC. 1675 MACARTHUR BLVD. COSTA MESA, CA 92626

Title: **RAVE Analog Inputs # 0-1**

Size: **B** Number: **SH-000864-00** Rev: **A**

File: C:\DATA\SCH\RAVE\Analog\Working\RAVE_beta2\864A\all\864A_all.DDB - Documents\qsc\ca\0.sch

Date: 11-Jan-2002 Eng: DARRYL HOCH Sheet 14 of 35

THIS DOCUMENT CONTAINS PROPRIETARY INFORMATION WHICH IS THE PROPERTY OF QSC AUDIO PRODUCTS. THAT MAY NOT BE DISCLOSED, REPRODUCED OR USED WITHOUT EXPRESS WRITTEN CONSENT FROM QSC AUDIO PRODUCTS.

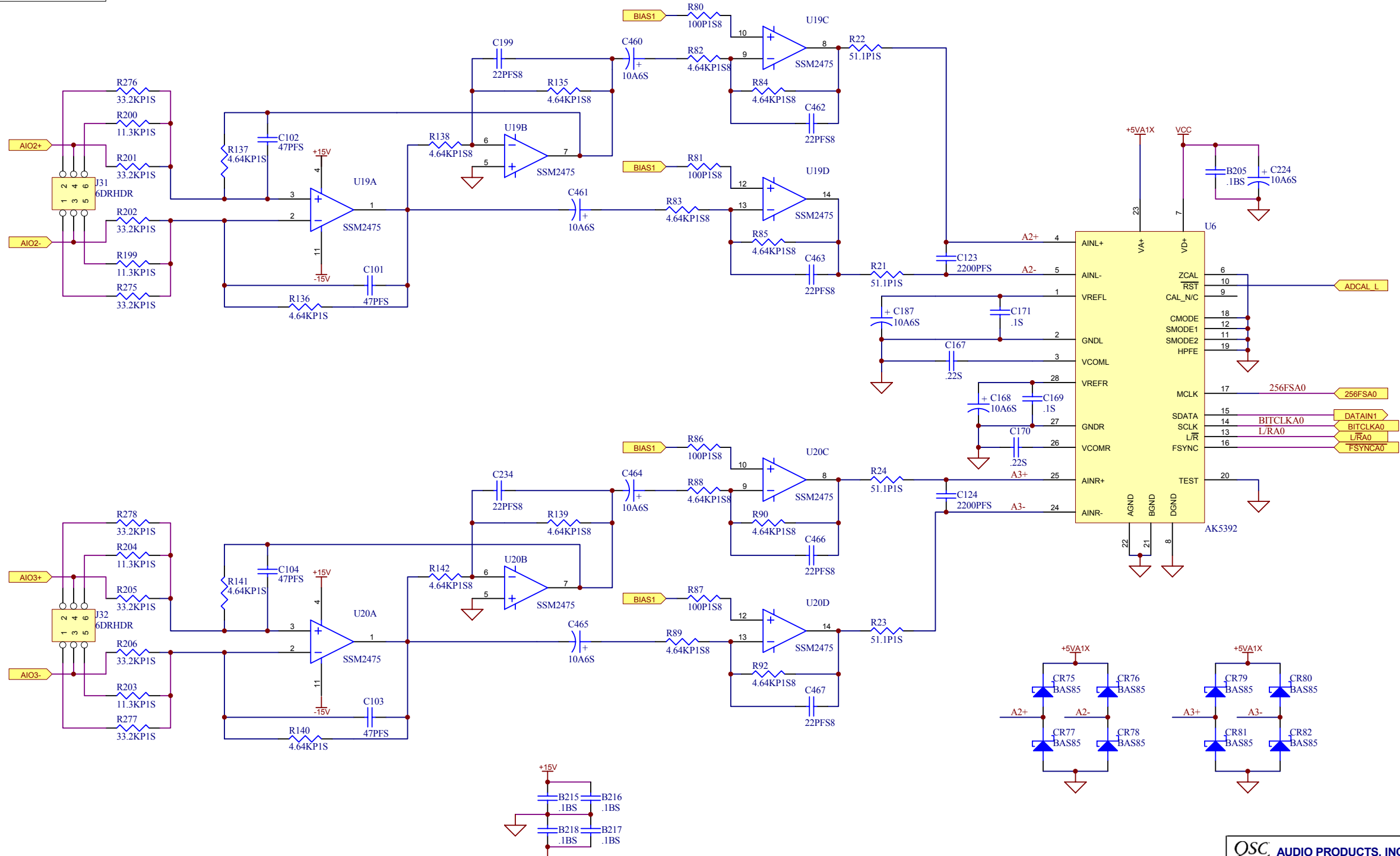

QSC AUDIO PRODUCTS, INC. 1675 MACARTHUR BLVD. COSTA MESA, CA 92626

Title: **RAVE Analog Inputs # 2-3**

Size: **B** Number: **SH-000864-00** Rev: **A**

File: C:\DATA\SH\RAVE\Analog\Working\RAVE_beta2\864A\all\864A_all.DDB - Documents\qspa\cai1.sch

Date: 11-Jan-2002 Eng: DARRYL HOCH Sheet 15 of 35

THIS DOCUMENT CONTAINS PROPRIETARY INFORMATION WHICH IS THE PROPERTY OF QSC AUDIO PRODUCTS. THAT MAY NOT BE DISCLOSED, REPRODUCED OR USED WITHOUT EXPRESS WRITTEN CONSENT FROM QSC AUDIO PRODUCTS.

Metering LED drivers

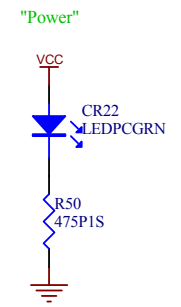
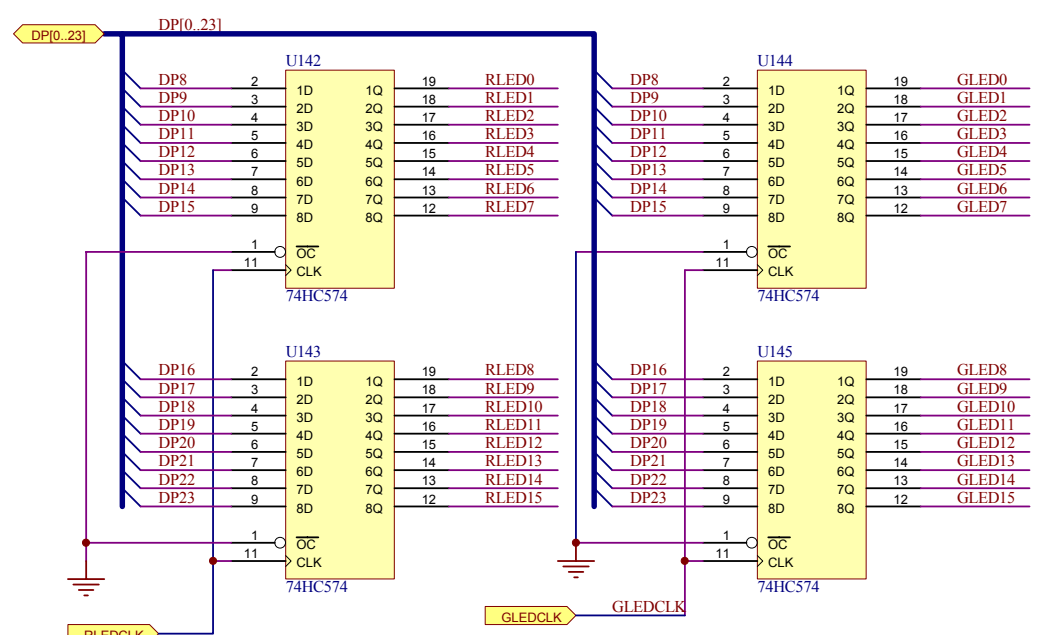

CobraNet status indicators (front panel)

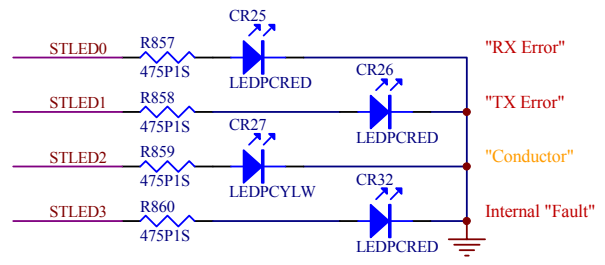

Status LED drivers and DAC functions (relay and mute control)

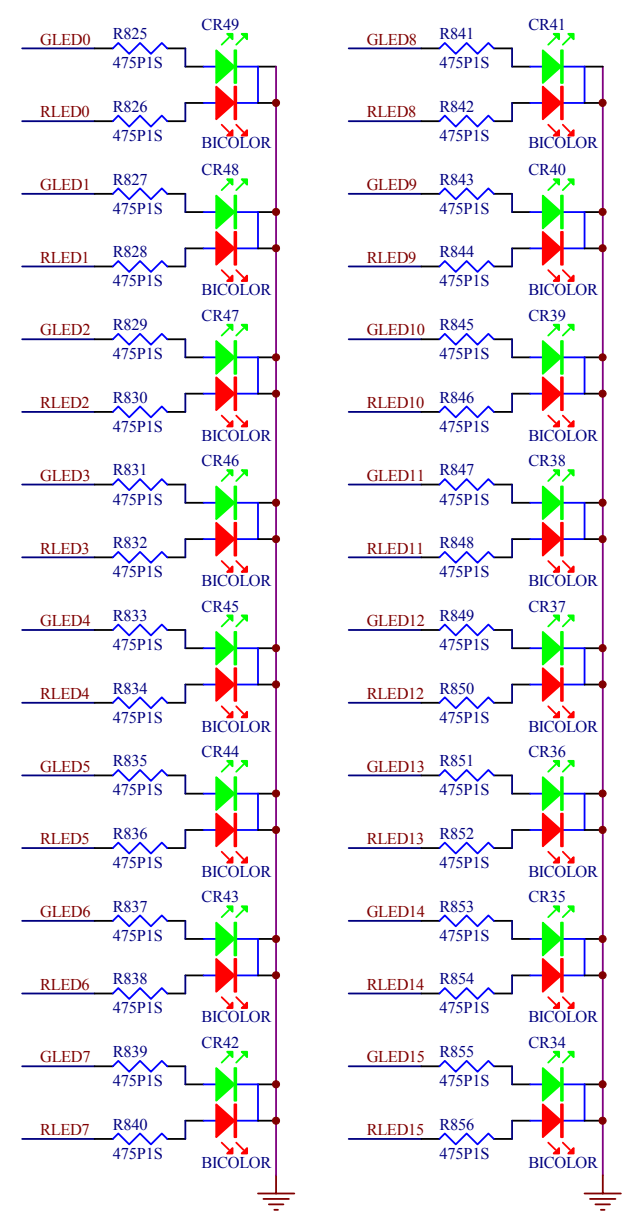
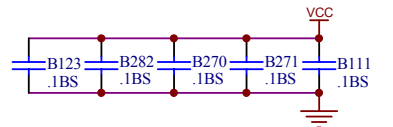
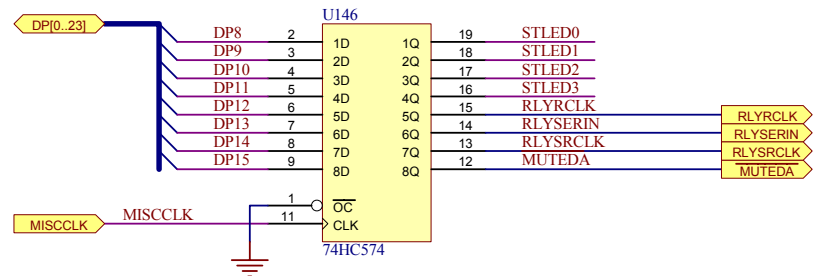

Metering, error code and version display LEDs (tri-color)

QSC AUDIO PRODUCTS, INC. 1675 MACARTHUR BLVD. COSTA MESA, CA 92626

Title: **RAVE Analog, LED & Relay Logic**

Size: **B** Number: **SH-000864-00** Rev: **A**

File: C:\DATA\SCH\RAVE\Analog\Working\RAVE_beta2\864A\all\864A_all.DDB - Documents\qspaCled.sch

Date: 11-Jan-2002 Eng: DARRYL HOCH Sheet 16 of 35

THIS DOCUMENT CONTAINS PROPRIETARY INFORMATION WHICH IS THE PROPERTY OF QSC AUDIO PRODUCTS. THAT MAY NOT BE DISCLOSED, REPRODUCED OR USED WITHOUT EXPRESS WRITTEN CONSENT FROM QSC AUDIO PRODUCTS.

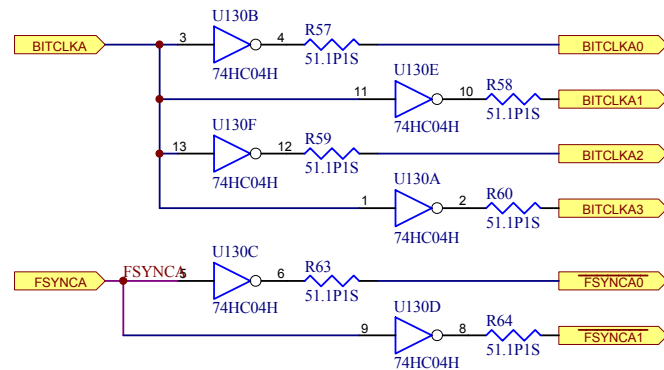
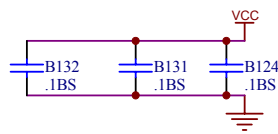

Independent "bit clocks" for audio converters (128FS)

Inverted "frame synch" control for multiplexing two converters onto each SSI stream (2FS)

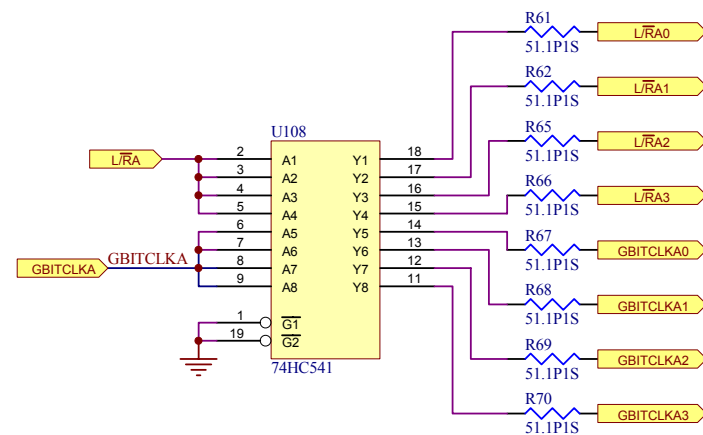

Independent "L/R" clocks for audio converters (FS)

Independent gated "bit clocks" for even numbered DACs (128FS)

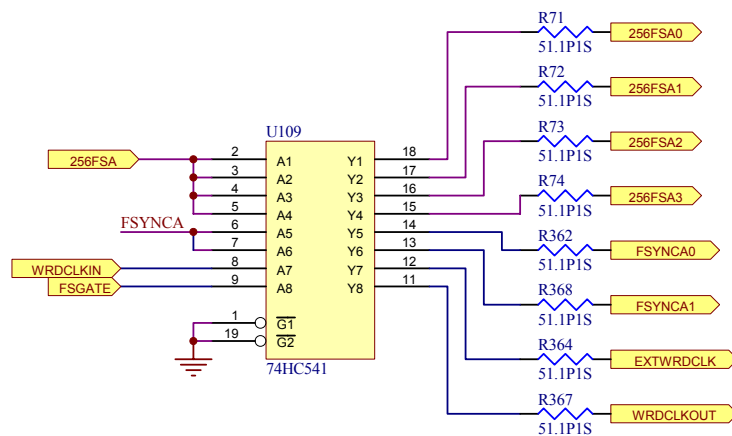

Independent "master" clocks for audio converters (256FS)

"Frame synch" control for multiplexing two converters onto each SSI stream (2FS)

External word clock from BNC input (750 Hz to FS)

Word clock to drive BNC output (Buddy Link and synchronization driver) (FS)

QSC AUDIO PRODUCTS, INC. 1675 MACARTHUR BLVD. COSTA MESA, CA 92626

Title: **RAVE Analog I/O Signal Drivers**

Size: **B** Number: **SH-000864-00** Rev: **A**

File: C:\DATA\SH\RAVE\Analog\Working\RAVE_beta2\864A\all\864A_all.DDB - Documents\qsc\catg.sch

Date: 11-Jan-2002 Eng: DARRYL HOCH Sheet 17 of 35

THIS DOCUMENT CONTAINS PROPRIETARY INFORMATION WHICH IS THE PROPERTY OF QSC AUDIO PRODUCTS. THAT MAY NOT BE DISCLOSED, REPRODUCED OR USED WITHOUT EXPRESS WRITTEN CONSENT FROM QSC AUDIO PRODUCTS.

24-bit serial audio from ADCs (U7 and U8) to DSP data bus

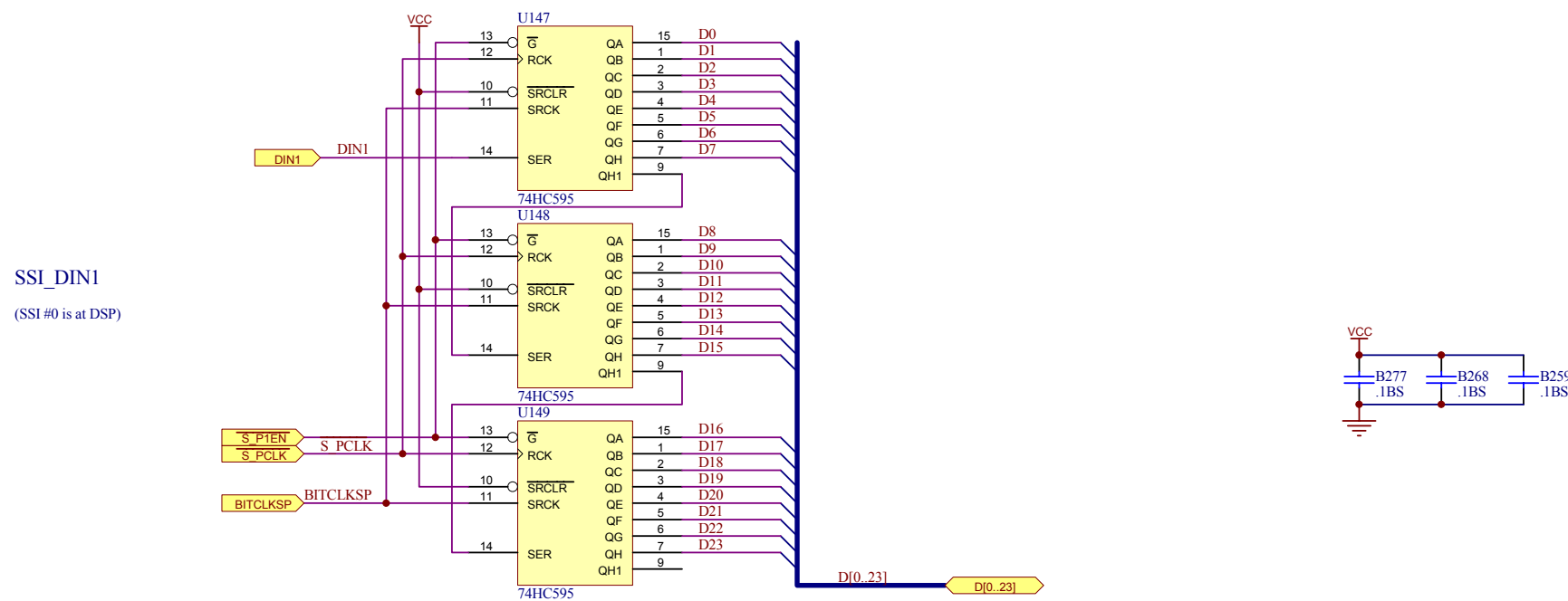

Serial data (SDATA) outputs from ADCs

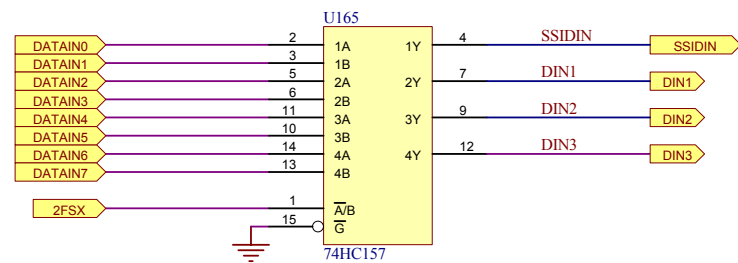

SSI data in streams (0..3)

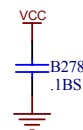

QSC AUDIO PRODUCTS, INC.		1675 MACARTHUR BLVD. COSTA MESA, CA 92626	
Title: RAVE Analog Input Multiplexer #0			
Size: B	Number: SH-000864-00	Rev A	
File: C:\DATA\SCH\RAVE\Analog\Working\RAVE_beta2\864A\all\864A_all.DDB - Documents\qspaCmux.sch			
Date: 11-Jan-2002	Eng: DARRYL HOCH	Sheet 18 of 35	

THIS DOCUMENT CONTAINS PROPRIETARY INFORMATION WHICH IS THE PROPERTY OF QSC AUDIO PRODUCTS. THAT MAY NOT BE DISCLOSED, REPRODUCED OR USED WITHOUT EXPRESS WRITTEN CONSENT FROM QSC AUDIO PRODUCTS.

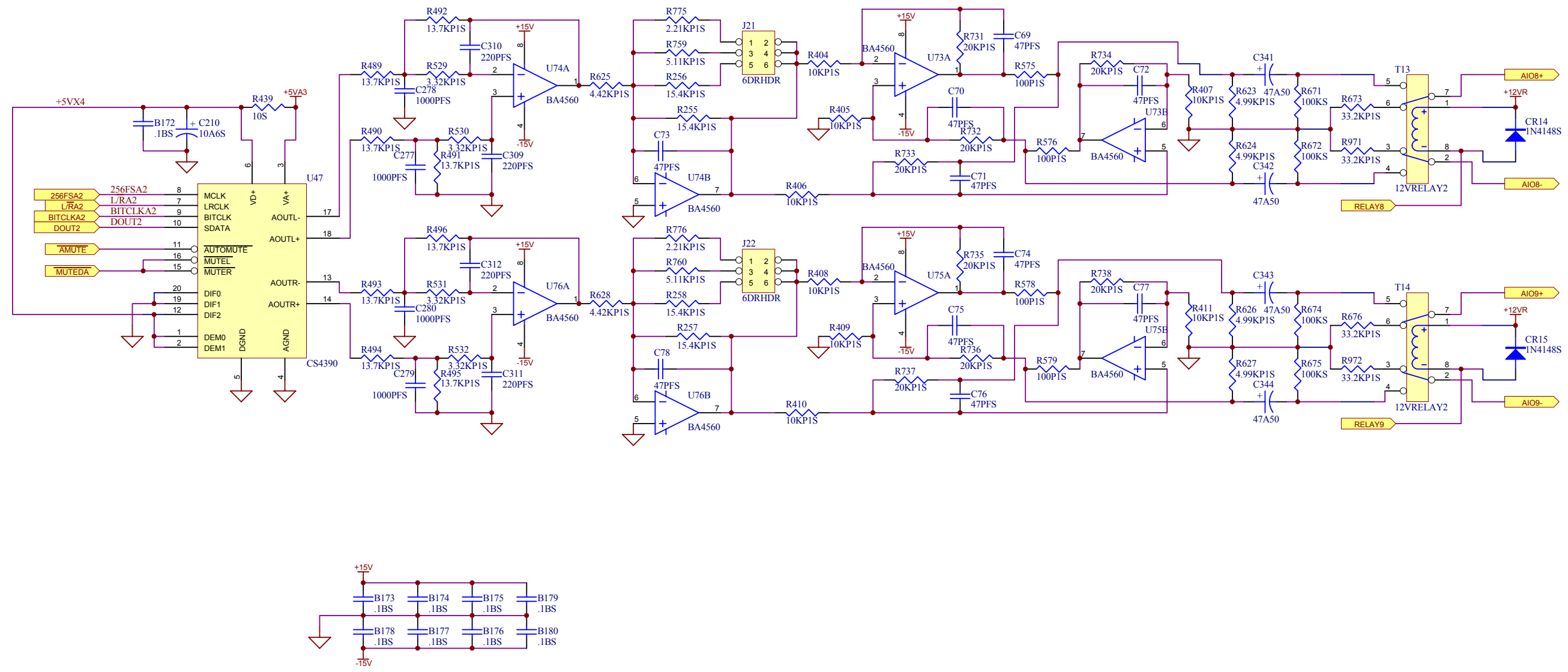

QSC AUDIO PRODUCTS, INC. 1675 MACARTHUR BLVD. COSTA MESA, CA 92626

Title: **RAVE Analog, Outputs #8-9**

Size: **B** Number: **SH-000864-00** Rev: **A**

File: C:\DATA\SH\RAVE\Analog\Working\RAVE_beta2\864A\all\864A_all.DDB - Documents\qspaCao4.sch

Date: 11-Jan-2002 Eng: DARRYL HOCH Sheet 23 of 35

THIS DOCUMENT CONTAINS PROPRIETARY INFORMATION WHICH IS THE PROPERTY OF QSC AUDIO PRODUCTS. THAT MAY NOT BE DISCLOSED, REPRODUCED OR USED WITHOUT EXPRESS WRITTEN CONSENT FROM QSC AUDIO PRODUCTS.

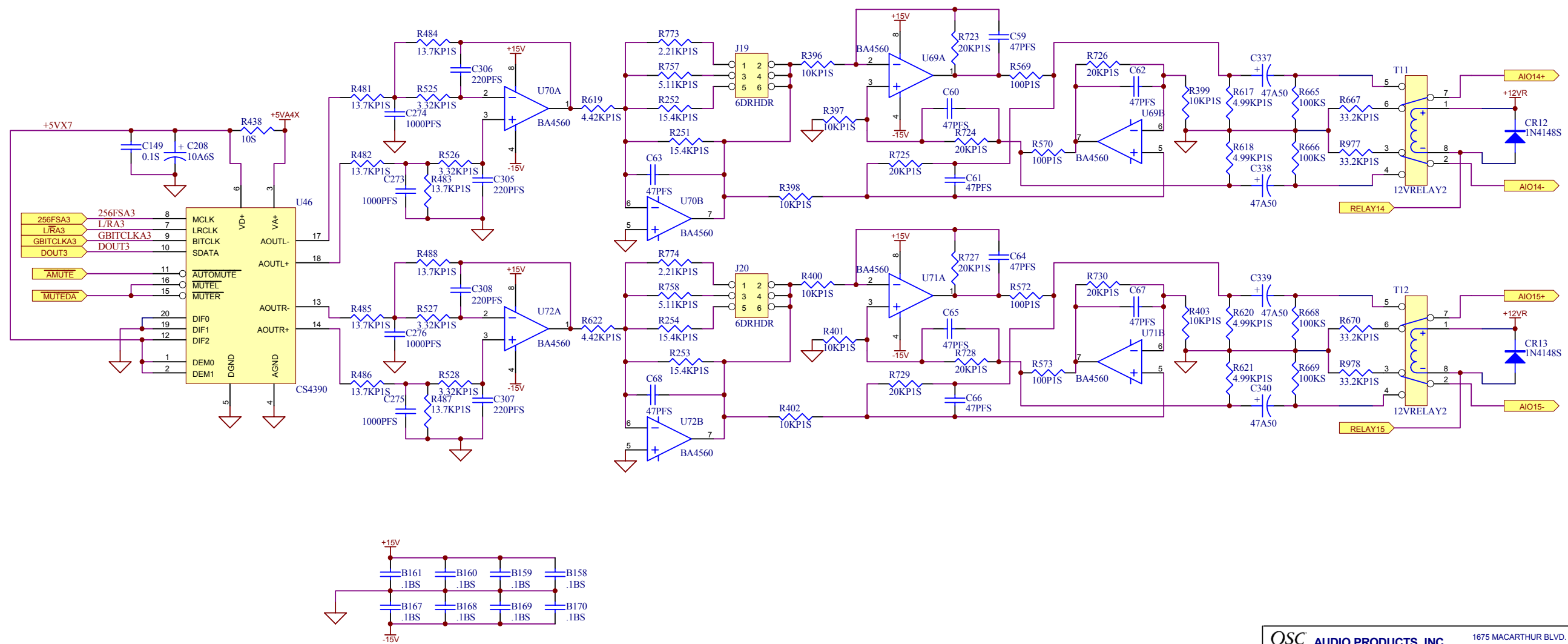

QSC AUDIO PRODUCTS, INC. 1675 MACARTHUR BLVD. COSTA MESA, CA 92626

Title: **RAVE Analog Outputs #14-15**

Size: **B** Number: **SH-000864-00** Rev: **A**

File: C:\DATA\SCH\RAVE\Analog\Working\RAVE_beta2\864A\all\864A_all.DDB - Documents\qspaCao7.sch

Date: 11-Jan-2002 Eng: DARRYL HOCH Sheet 24 of 35

THIS DOCUMENT CONTAINS PROPRIETARY INFORMATION WHICH IS THE PROPERTY OF QSC AUDIO PRODUCTS. THAT MAY NOT BE DISCLOSED, REPRODUCED OR USED WITHOUT EXPRESS WRITTEN CONSENT FROM QSC AUDIO PRODUCTS.

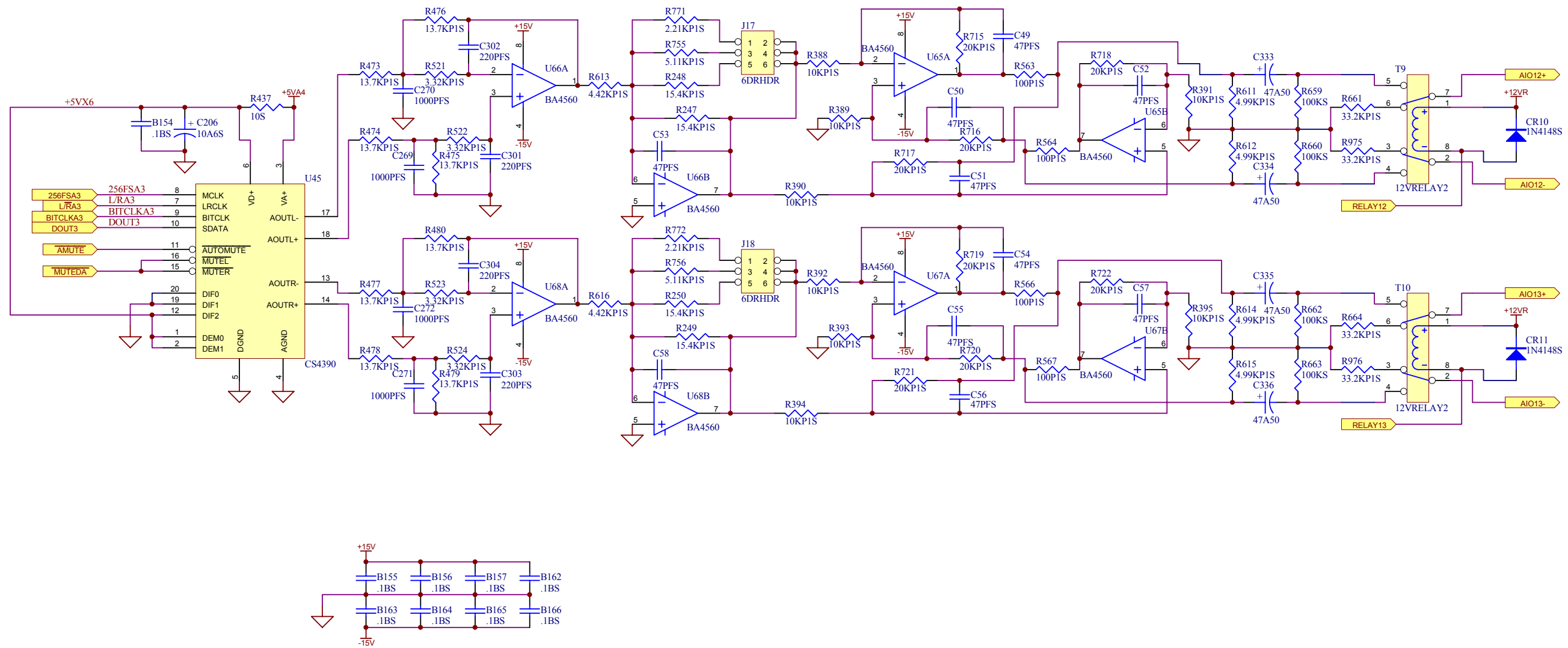

QSC AUDIO PRODUCTS, INC. 1675 MACARTHUR BLVD. COSTA MESA, CA 92626

Title: **RAVE Analog Outputs #12-13**

Size: **B** Number: **SH-000864-00** Rev: **A**

File: C:\DATA\SCH\RAVE\Analog\Working\RAVE_beta2\864A\all\864A_all.DDB - Documents\qspaCao6.sch

Date: 11-Jan-2002 Eng: DARRYL HOCH Sheet 25 of 35

THIS DOCUMENT CONTAINS PROPRIETARY INFORMATION WHICH IS THE PROPERTY OF QSC AUDIO PRODUCTS. THAT MAY NOT BE DISCLOSED, REPRODUCED OR USED WITHOUT EXPRESS WRITTEN CONSENT FROM QSC AUDIO PRODUCTS.

24-bit audio from DSP to serial data in at DACs (U43 and U44)

Output relay drivers (bank 2)

SSI_DOUT1
(SSI #0 is at DSP)

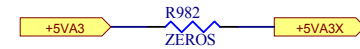
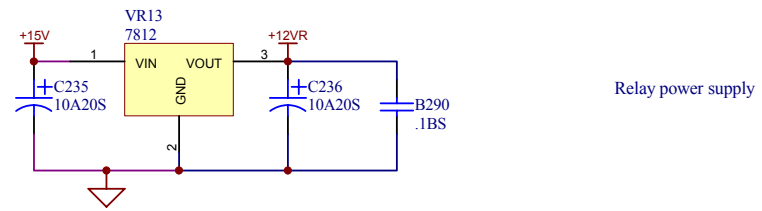
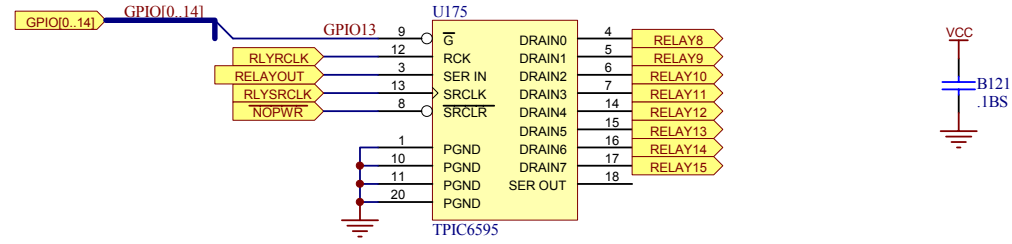
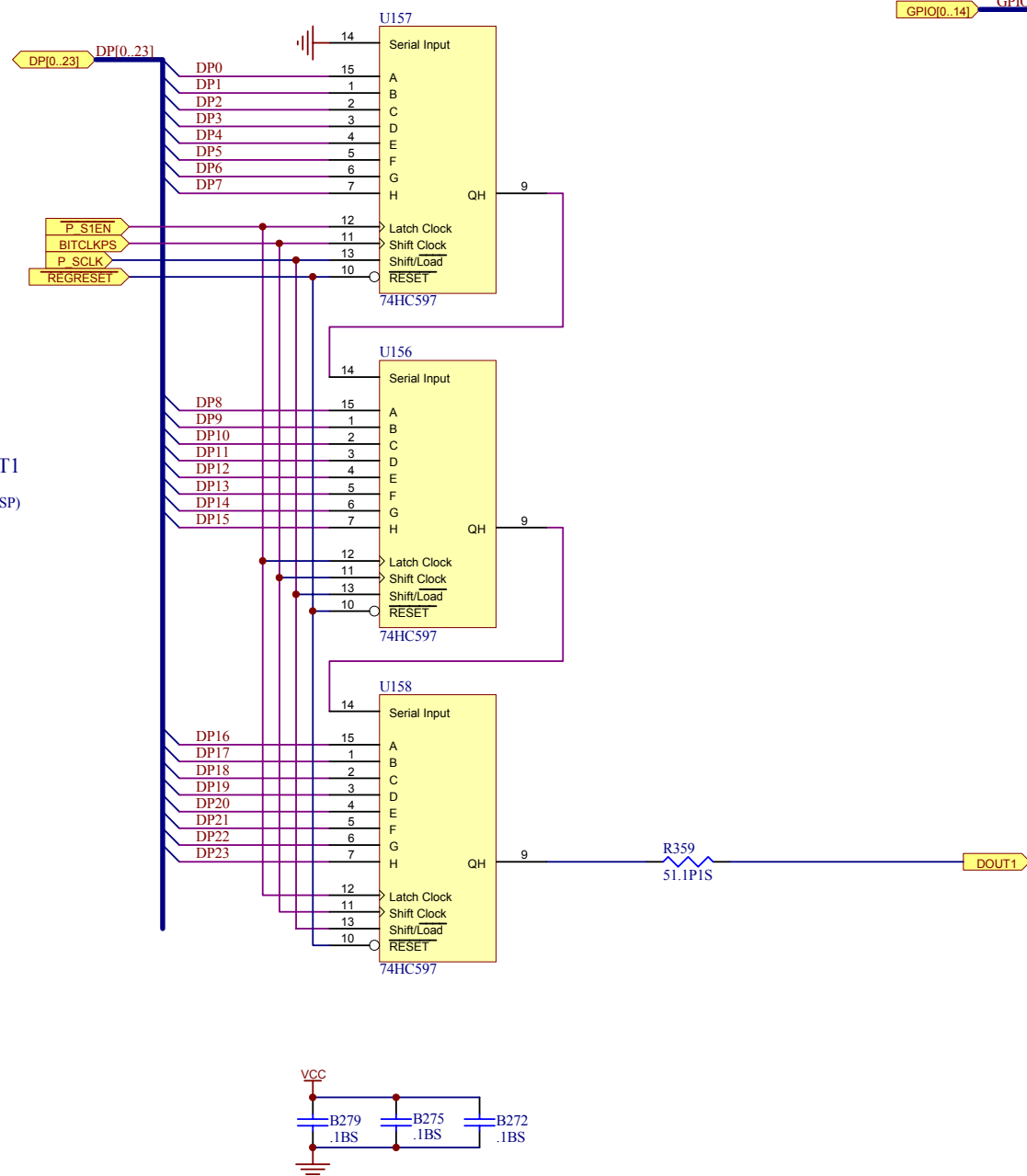

Bridge for single +5 V source for DACs (U47 and U48)

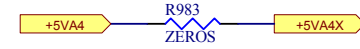

Bridge for single +5 V source for DACs (U45 and U46)

QSC AUDIO PRODUCTS, INC.		1675 MACARTHUR BLVD. COSTA MESA, CA 92626	
Title: RAVE Analog, P/S #1 & Relay			
Size: B	Number: SH-000864-00	Rev A	
File: C:\DATA\SCH\RAVE\Analog\Working\RAVE_beta2\864A\all\864A_all.DDB - Documents\qspaCm01.sch			
Date: 11-Jan-2002	Eng: DARRYL HOCH	Sheet 26 of 35	

THIS DOCUMENT CONTAINS PROPRIETARY INFORMATION WHICH IS THE PROPERTY OF QSC AUDIO PRODUCTS. THAT MAY NOT BE DISCLOSED, REPRODUCED OR USED WITHOUT EXPRESS WRITTEN CONSENT FROM QSC AUDIO PRODUCTS.

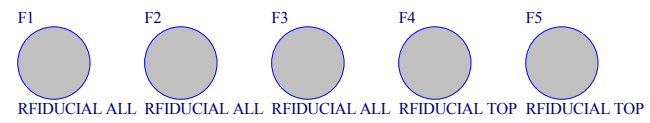
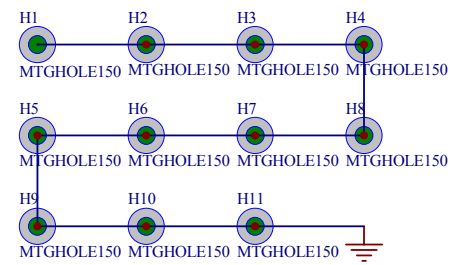

QSC AUDIO PRODUCTS, INC.		1675 MACARTHUR BLVD. COSTA MESA, CA 92626	
Title: RAVE Analog, Mech & Spare Cmpnt			
Size: B	Number: SH-00864-00	Rev A	
File: C:\DATA\SCH\RAVE\Analog\Working\RAVE_beta2\864A\all\864A_all.DDB - Documents\qspaCmec.sch			
Date: 11-Jan-2002	Eng: DARRYL HOCH	Sheet 29 of 35	

THIS DOCUMENT CONTAINS PROPRIETARY INFORMATION WHICH IS THE PROPERTY OF QSC AUDIO PRODUCTS. THAT MAY NOT BE DISCLOSED, REPRODUCED OR USED WITHOUT EXPRESS WRITTEN CONSENT FROM QSC AUDIO PRODUCTS.

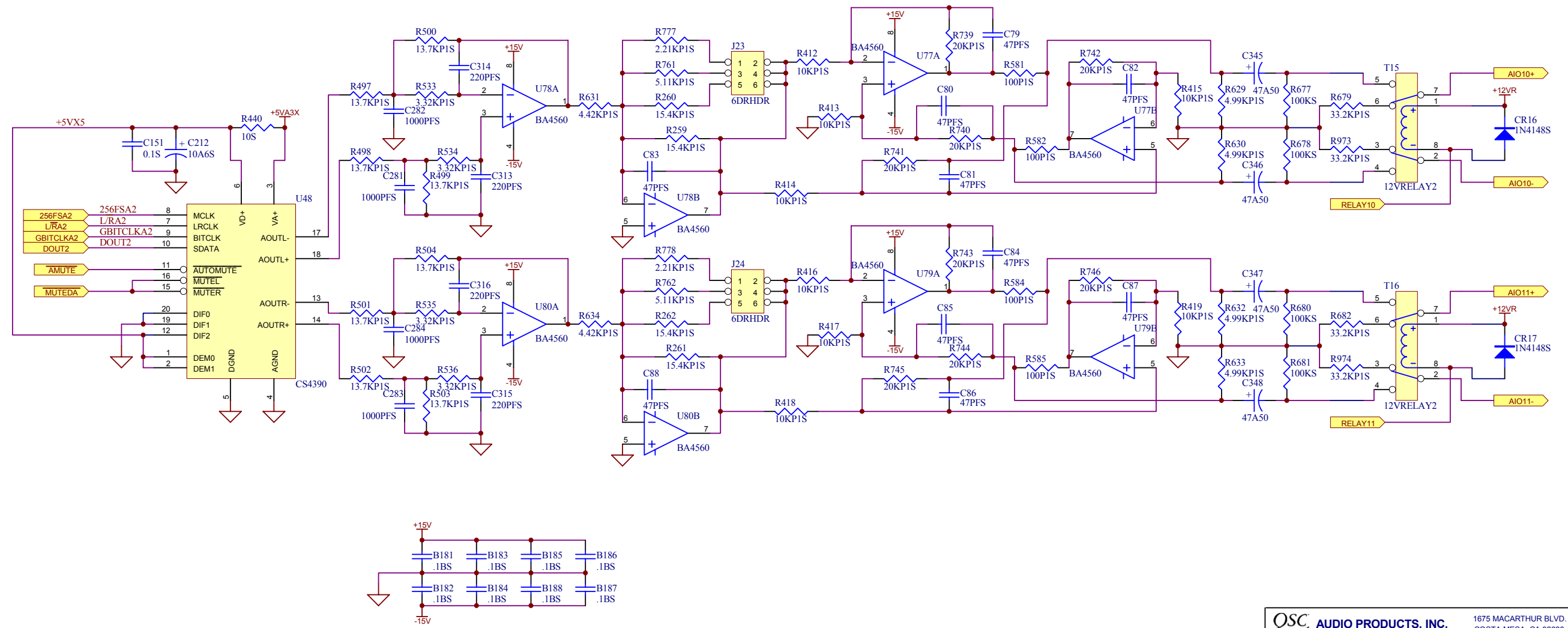

QSC AUDIO PRODUCTS, INC. 1675 MACARTHUR BLVD. COSTA MESA, CA 92626

Title: **RAVE Analog Outputs #10-11**

Size: **B** Number: **SH-000864-00** Rev: **A**

File: C:\DATA\SCHRAVE\Analog\Working\RAVE_beta2\864A\all\864A_all.DDB - Documents\qspaCao5.sch

Date: 11-Jan-2002 Eng: DARRYL HOCH Sheet 30 of 35

THIS DOCUMENT CONTAINS PROPRIETARY INFORMATION WHICH IS THE PROPERTY OF QSC AUDIO PRODUCTS. THAT MAY NOT BE DISCLOSED, REPRODUCED OR USED WITHOUT EXPRESS WRITTEN CONSENT FROM QSC AUDIO PRODUCTS.

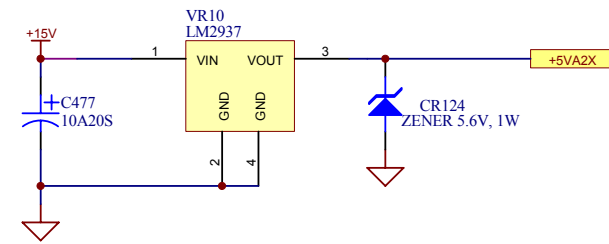
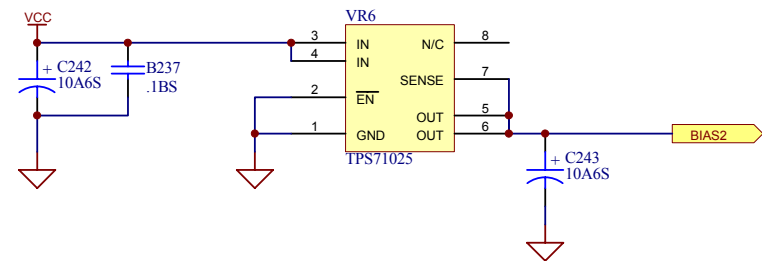
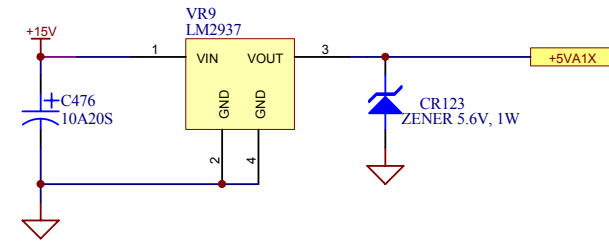
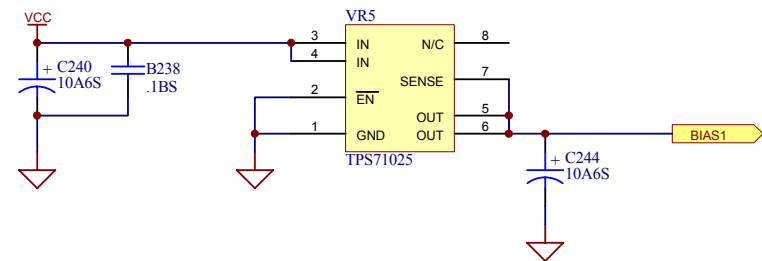

SSI swap for RAVE 188s-24
(Channel 1 output goes to PCB output 9)

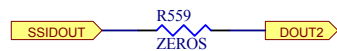

SSI swap for RAVE 188s-24
(Channel 5 output goes to PCB output 13)

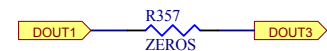

QSC AUDIO PRODUCTS, INC.		1675 MACARTHUR BLVD. COSTA MESA, CA 92626	
Title: RAVE Analog, +2.5V Voltage Reg			
Size: B	Number: SH-000864-00	Rev A	
File: C:\DATA\SCH\RAVE\Analog\Working\RAVE_beta2\864A\all\864A_all.DDB - Documents\qspaCvr2.sch			
Date: 11-Jan-2002	Eng: DARRYL HOCH	Sheet 32 of 35	

THIS DOCUMENT CONTAINS PROPRIETARY INFORMATION WHICH IS THE PROPERTY OF QSC AUDIO PRODUCTS. THAT MAY NOT BE DISCLOSED, REPRODUCED OR USED WITHOUT EXPRESS WRITTEN CONSENT FROM QSC AUDIO PRODUCTS.

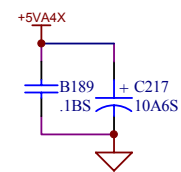
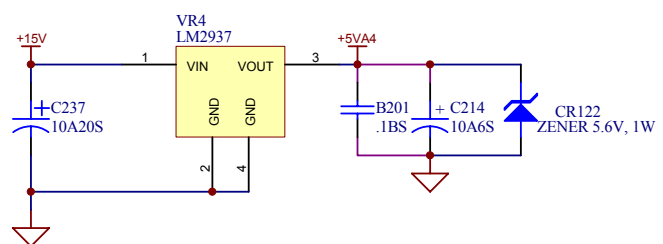
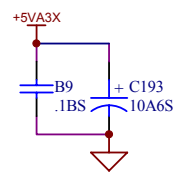
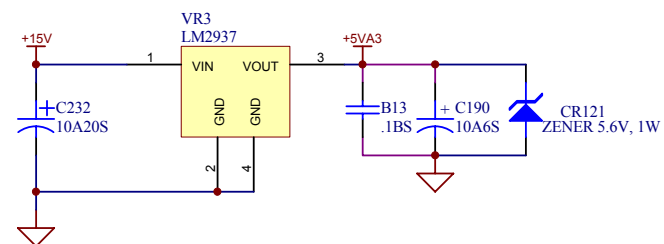
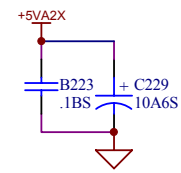
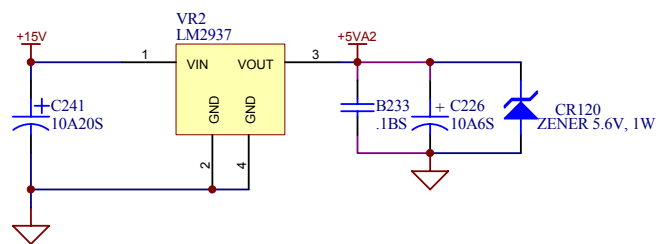
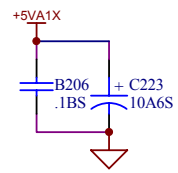
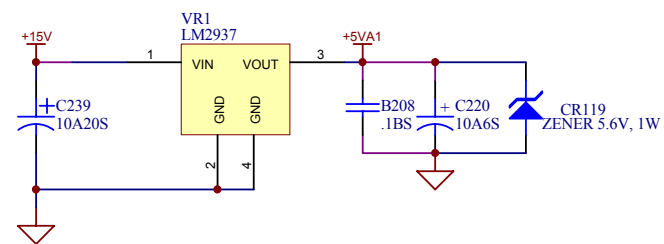

QSC AUDIO PRODUCTS, INC. 1675 MACARTHUR BLVD.
COSTA MESA, CA 92626

Title: **RAVE Analog, +5V Voltage Reg**

Size: **B** Number: **SH-000864-00** Rev **A**

File: C:\DATA\SHIRAVE\Analog\Working\RAVE_beta2\864A\all\864A_all.DDB - Documents\qspaCvvp.sch

Date: 11-Jan-2002 Eng: DARRYL HOCH Sheet 33 of 35

THIS DOCUMENT CONTAINS PROPRIETARY INFORMATION WHICH IS THE PROPERTY OF QSC AUDIO PRODUCTS. THAT MAY NOT BE DISCLOSED, REPRODUCED OR USED WITHOUT EXPRESS WRITTEN CONSENT FROM QSC AUDIO PRODUCTS.

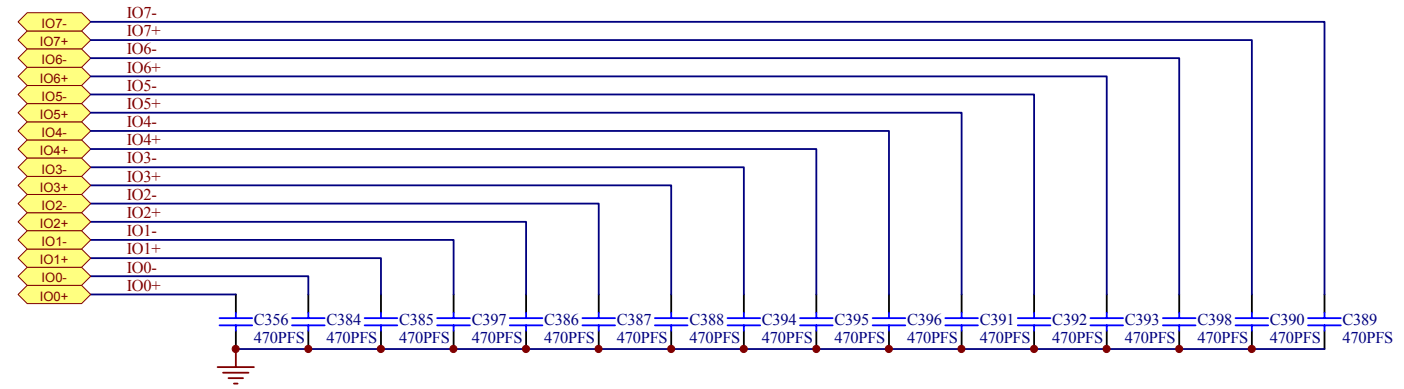

Bank 2 relay driver becomes bank 1 on RAVE 188s-24
R49 bypasses relay drive daisy chain on bank 1

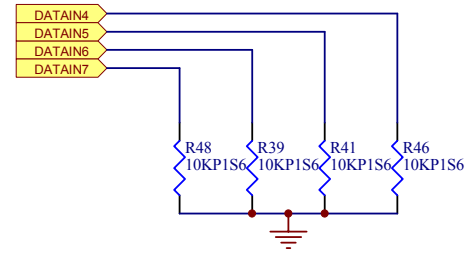

Audio multiplexer's input pulldowns.
Terminates serial data outputs when ADCs U1 through U4 are not stuffed.

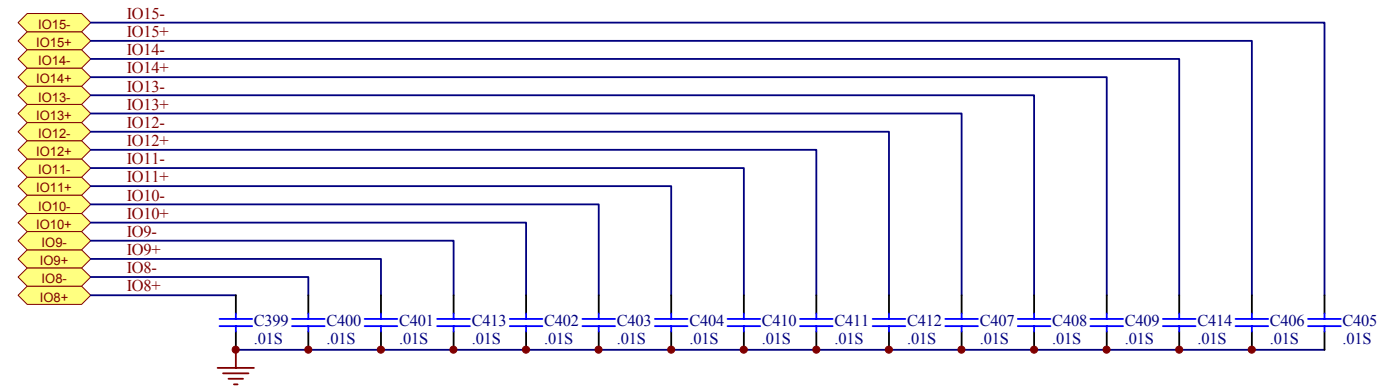

QSC AUDIO PRODUCTS, INC. 1675 MACARTHUR BLVD. COSTA MESA, CA 92626

Title: **RAVE Analog, 188 I/O caps**

Size: **B** Number: **Sh-000864-00** Rev: **A**

File: C:\DATA\SCH\RAVE\Analog\Working\RAVE_beta2\864A\all\864A_all.DDB - Documents\qspaCcp8.sch

Date: 11-Jan-2002 Eng: DARRYL HOCH Sheet 34 of 35

THIS DOCUMENT CONTAINS PROPRIETARY INFORMATION WHICH IS THE PROPERTY OF QSC AUDIO PRODUCTS. THAT MAY NOT BE DISCLOSED, REPRODUCED OR USED WITHOUT EXPRESS WRITTEN CONSENT FROM QSC AUDIO PRODUCTS.

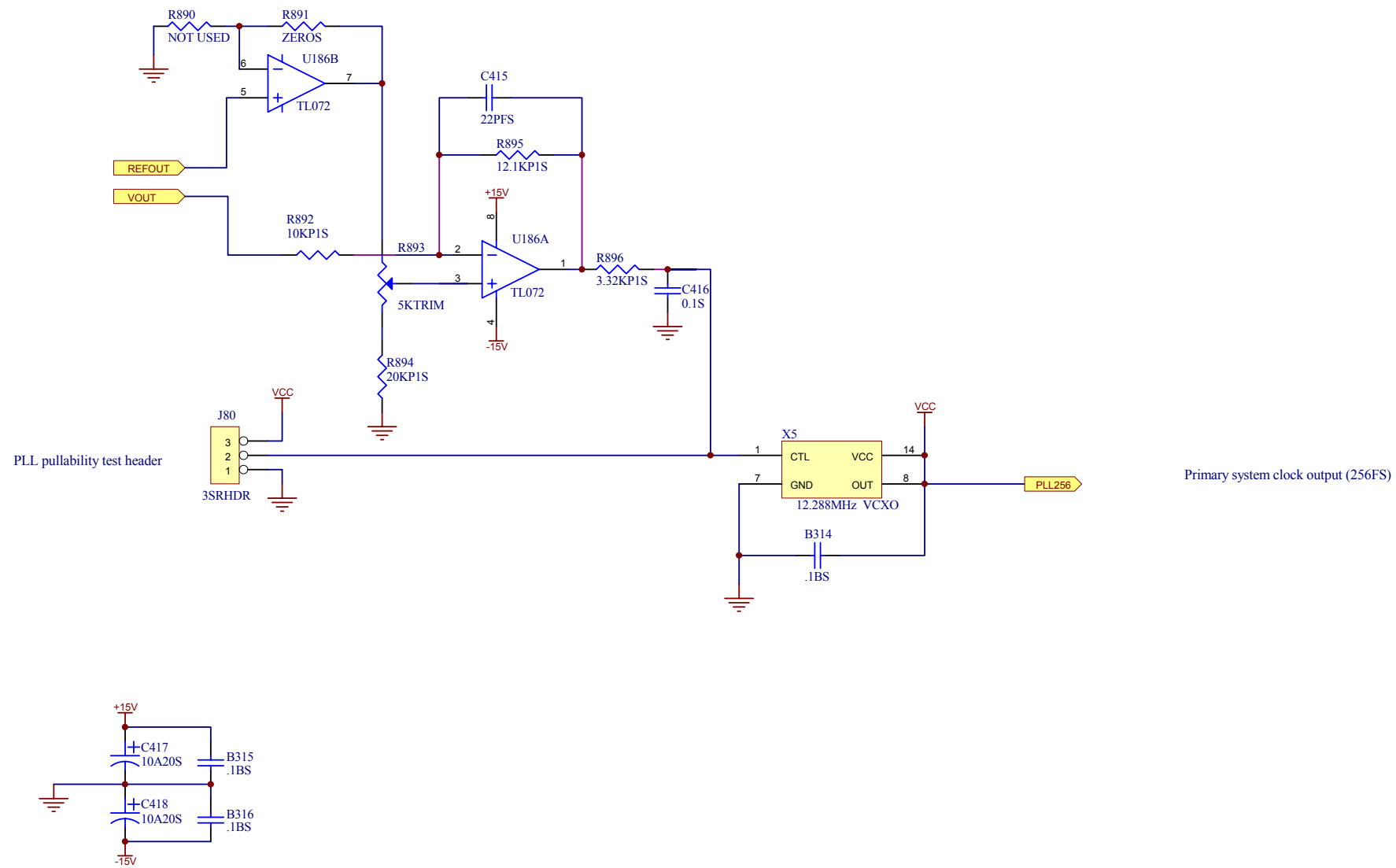

QSC AUDIO PRODUCTS, INC. 1675 MACARTHUR BLVD. COSTA MESA, CA 92626

Title: RAVE Analog PLL / VCXO

Size: B Number: SH-000864-00 Rev: A

File: C:\DATA\SCH\RAVE\Analog\Working\RAVE_beta2\864A\all\864A_all.DDB - Documents\qspaCpl1.sch

Date: 11-Jan-2002 Eng: DARRYL HOCH Sheet 35 of 35