

THIS DOCUMENT CONTAINS PROPRIETARY INFORMATION WHICH IS THE PROPERTY OF QSC AUDIO PRODUCTS, THAT MAY NOT BE DISCLOSED, REPRODUCED OR USED WITHOUT EXPRESS WRITTEN CONSENT FROM QSC AUDIO PRODUCTS.

REVISIONS				
REV	DESCRIPTION	EFF DATE	CHK	APPROVED DATE
G	REVISED PER ECO 6480 JEE	2-18-05		DD
H	REVISED PER ECO 6593 MP	5-27-05		DD
K	REVISED PER ECO 6742 MP	8-19-05		DD
K1	REVISED PER ECO 6781 MP	9-16-05		DD
K2	REVISED PER ECO 7394 MP	8-25-06		DD
L	REVISED PER ECO 8087 MP	6-22-07		DD

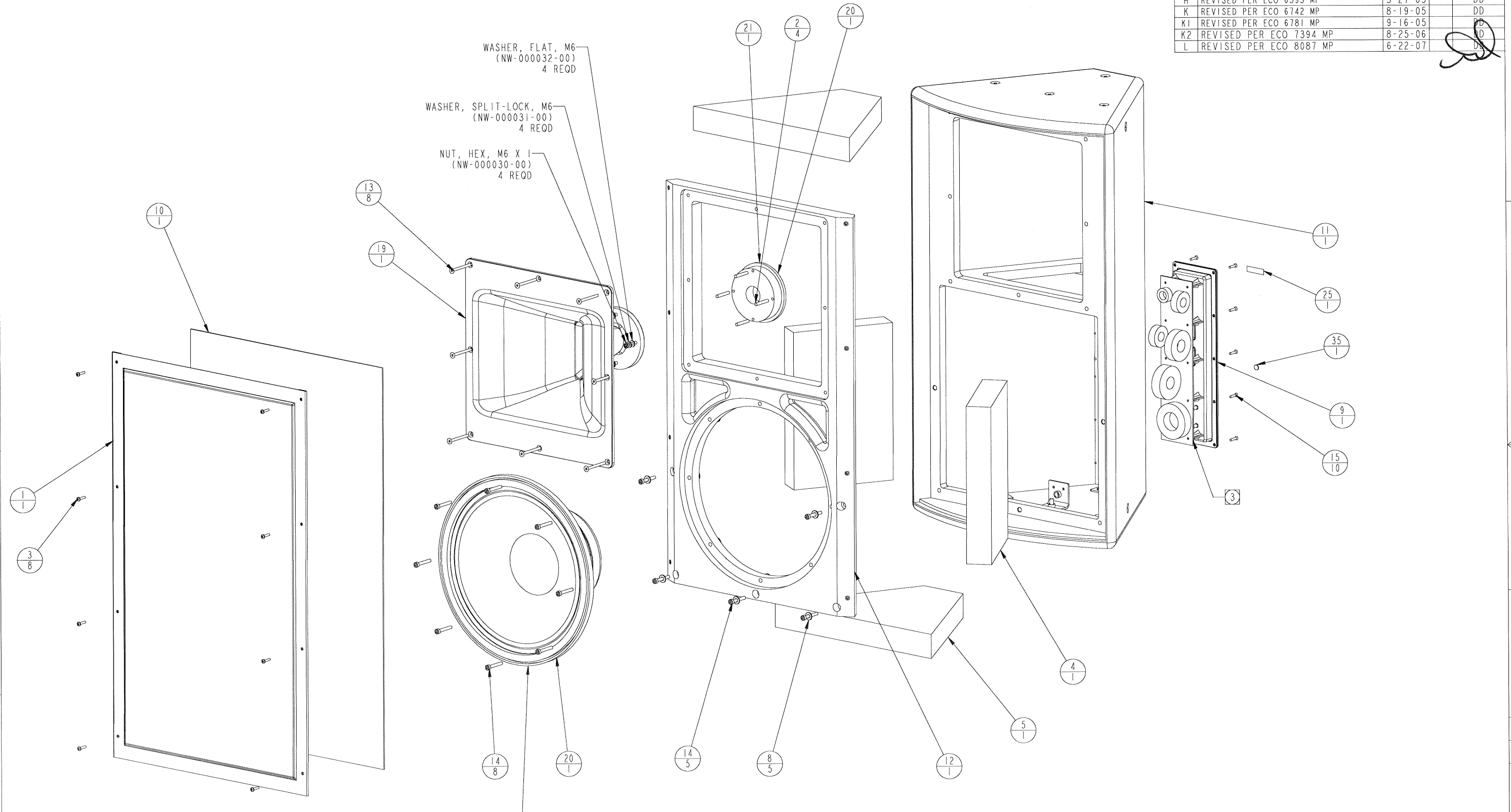

3 REFER TO APPROPRIATE ASSEMBLY AID FOR THE PROPER PLACEMENT OF ATTACHED HEAT SINK/RESISTOR ASSEMBLY.

2. SPRAY ADHESIVE GLUE UNDER DAMPENING MATERIAL AND FOAM.  
 1. ASSEMBLE ADHESIVE GASKET UNDER WOOFER AND BAFFLE.

NOTE: UNLESS OTHERWISE SPECIFIED DRIVER ASSY, MATCHED PAIR, 15PS40/DE610 (WP-000137-00)

WASHER, FLAT, M6 (NW-000032-00) 4 REQD  
 WASHER, SPLIT-LOCK, M6 (NW-000031-00) 4 REQD  
 NUT, HEX, M6 X 1 (NW-000030-00) 4 REQD

UNLESS OTHERWISE SPECIFIED DIMENSIONS ARE IN INCHES.		CONTRACT NO.		QSC QSC AUDIO PRODUCTS, INC. 1675 MACARTHUR BOULEVARD COSTA MESA, CA 92626	
TOLERANCES ARE: DECIMALS DECIMALS ANGLES .XX ±.02 .XXX ±.010 ±1/2 DEBURR EDGES .010 R MAX		APPROVALS		DATE	
MATERIAL NONE		DRAWN B. HAWKINS		12-05-03	
FINISH NONE		CHECKED P. WRIGHT		12-18-03	
DO NOT SCALE DRAWING		MFG ENG R. BALTHAZAR		12-11-03	
		ISSUED D. DELARM			
		SCALE 0.167		WP-015294-XX.L.0	
		SIZE D		CAGE CODE 00PW4	
		DWG NO. WP-015294-XX		REV L	
		SHEET 1 of 1		DRAWING INFO	

	COLOR
-01	BLACK
-02	WHITE

**Current BOM**  
**as of 27-JUN-07 11.33.27 AM**

Assembly Item Number: WP-015294-01	Assembly Description: SPEAKER ASSEMBLY, 15" 2-WAY, MD-F152/94R, BLACK,,90X40	Assembly Revision: L	Assy Rev Date: 22-JUN-07	Or
------------------------------------	--	----------------------	--------------------------	----

	Part Number	Rev	Description	Item No.	Eff Date	Qty	Op Sequence	Comments	Ref Des
1	CH-000396-01	B	GRILLE, TWO-PIECE, EMBOSSSED, MD SERIES, BLACK	1	03-DEC-2003	1.00	200		
2	HW-000067-00	B1	STUD, THREADED, M6, 37.5MM L, STEEL, BLK, PHS, 6219 LUBE,	2	21-NOV-2003	4.00	200		
3	SC-000013-00	B	PHILLIPS, PANHEAD SEMS, #8-32, 0.75" L, BLACK ZINC, STAINLESS STEEL, CR111	3	15-AUG-2005	8.00	200		
4	MS-000239-00	A1	INSULATION, FIBERGLASS, DAMPENING WOOD CABINET SPKR, 26" X 8.5" X 2",	4	19-AUG-2005	1.00	200		
5	MS-000240-00	A1	INSULATION, FIBERGLASS, DAMPENING WOOD CABINET SPKR, 26" X 11.5" X 2",	5	19-AUG-2005	1.00	200		
6	NW-000046-00	B1	WASHER, .625 OD .281 ID, .062 THK, TOL. +/- .010, STEEL BLACK ZINC W/6107 LUBE, CR111	8	16-JAN-2004	5.00	200		
7	PA-000091-00	E	TERMINAL CUP/XOVER ASSY, 15", 90 X 40, ,	9	21-NOV-2003	1.00	200		
8	PL-000359-01	B3	FOAM, GRILL, MD SERIES, , BLACK,	10	21-NOV-2003	1.00	200		
9	SB-000016-01	D	ENCLOSURE, W/RIGGING HARDWARE, MD SERIES, , BLACK,	11	21-NOV-2003	1.00	200		
10	SB-000026-00	D2	BAFFLE, 15" 2-WAY, , , ,	12	21-NOV-2003	1.00	200		
11	SC-000034-00	B	SOCKET, FLAT HEAD, M6, 1.0 X 60 MM, BLACK ZINC W/6107 LUBE, CR111	13	21-NOV-2003	8.00	200		
12	SC-000036-00	B	SOCKET HEAD CAP, , M6, 1.0 X 40 MM, BLACK ZINC W/6107 LUBE, CR111	14	21-NOV-2003	13.00	200		
13	SC-000039-00	B	PHILLIPS, FLAT HEAD, #8-32, 3/4, BLACK ZINC W/6107 LUBE, 100 DEG., CR111	15	21-NOV-2003	10.00	200		
14	SP-000053-00	B2	HORN, 90 X 40, , , ,	19	21-NOV-2003	1.00	200		
15	SP-000043-00	B1	WOOFER, 15", PAPER, FERRITE, B&C, 15PS40-8	20	19-AUG-2005	1.00	200		
16	SP-000044-00	B1	COMPRESSION DRIVER, 1.4", TITANIUM, NEO, B&C, DE610ND-8	21	19-AUG-2005	1.00	200		
17	RD-000158-00	L	LABEL, SERIAL NUMBER, SPEAKER, 1.7" X .45" IN-HOUSE	25	01-SEP-2006	0.00	200		
18	TP-015294-01	1	LOUDSPEAKER SYSTEM, TEST SPECIFICATION, MD-F152/94R,	30	25-JUL-2005	0.00	200		
19	LB-000673-50	A	LABEL, CHINA ROHS, 50 YEARS, , SMALL	35	22-JUN-2007	1.00	200		

THIS DOCUMENT CONTAINS PROPRIETARY INFORMATION WHICH IS THE PROPERTY OF QSC AUDIO PRODUCTS, THAT MAY NOT BE DISCLOSED, REPRODUCED OR USED WITHOUT EXPRESS WRITTEN CONSENT FROM QSC AUDIO PRODUCTS.

WASHER, FLAT, .467 OD .256 ID  
(NW-000032-00)  
4 REQD

WASHER, SPLIT-LOCK, M6  
(NW-000031-00)  
4 REQD

NUT, HEX, M6 X 1  
(NW-000030-00)  
4 REQD

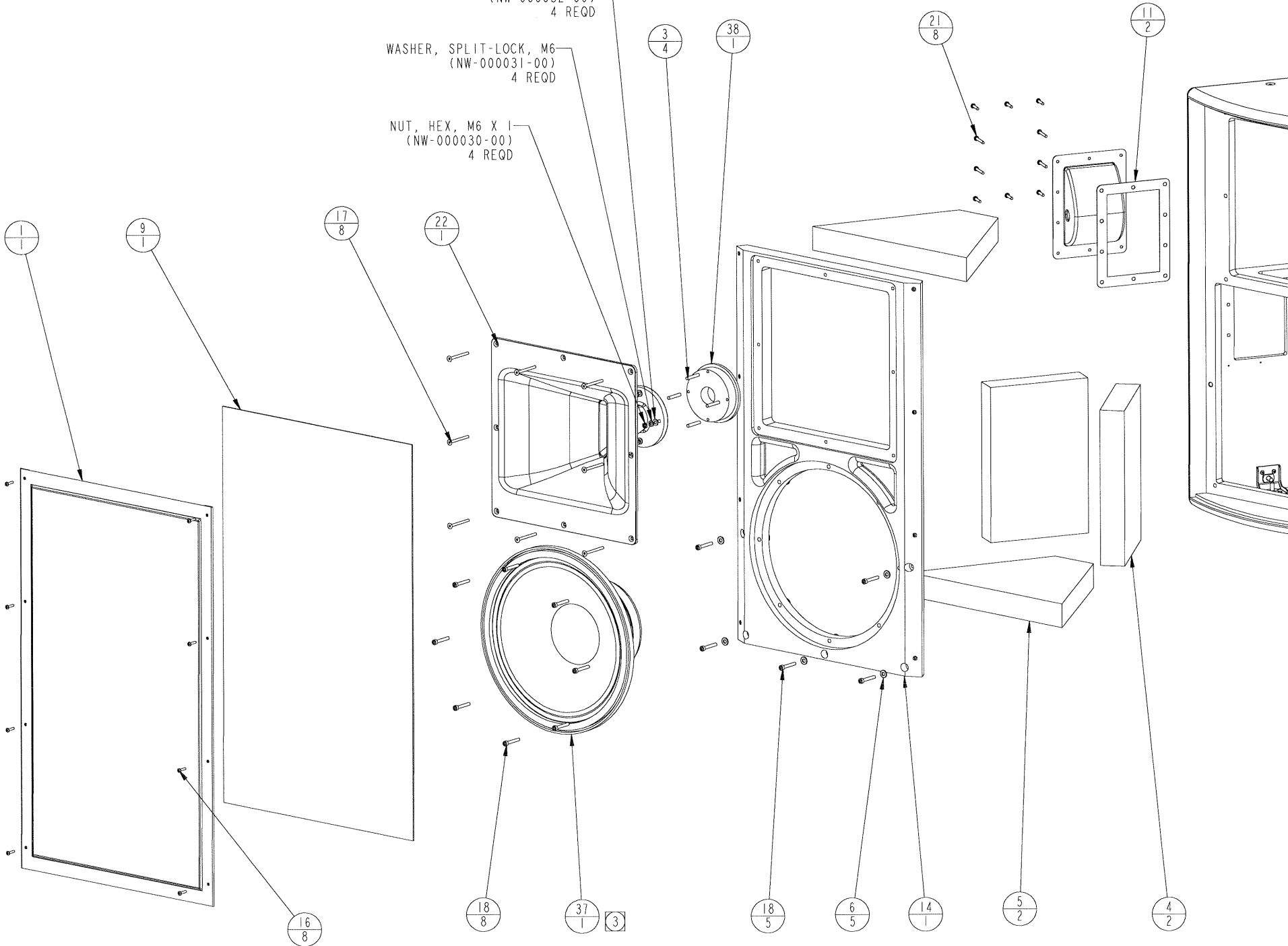

D

C

B