

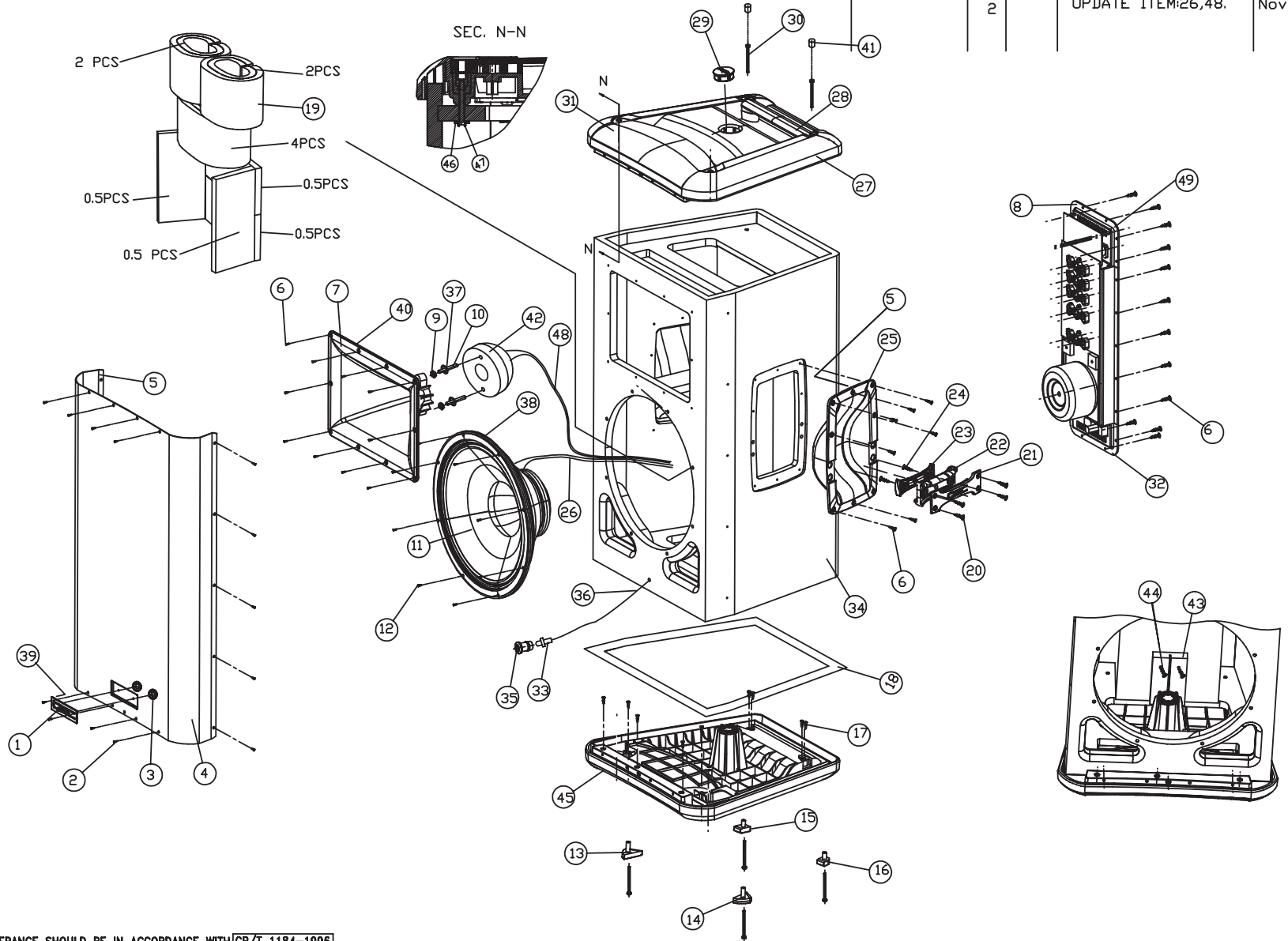

1 WORK TO DIMENSIONS. REMOVE ALL BURRS. ALL CASTINGS AND MOULDING TO BE FREE FROM SINKS AND BLEMISHES.

5	6	7	8	9
GPE EN. NO.	REV	ZONE	DESCRIPTION	DATE
	1 2		DRAWING RELEASE UPDATE ITEM:26,48.	Aug.16.06 Nov.29.06

THIS DOCUMENT CONTAINS PROPRIETARY INFORMATION WHICH IS THE PROPERTY OF QSC AUDIO PRODUCTS, THAT MAY NOT BE DISCLOSED, REPRODUCED OR USED WITHOUT EXPRESS WRITTEN CONSENT FROM QSC AUDIO PRODUCTS.



GEOMETRIC TOLERANCE & POSITIONAL TOLERANCE SHOULD BE IN ACCORDANCE WITH GB/T 1184-1996

QSC QSC AUDIO PRODUCTS, INC.
1675 MACARTHUR BOULEVARD
COSTA MESA, CA 92626

UNLESS OTHERWISE SPECIFIED : TOLERANCES ARE			MODEL USAGE	MATERIAL:	SIGNATURE	DATE	SIGNATURE	DATE	TITLE: HPR152i EXPLODED DRAWING			
1 decimal place	±0.1mm	31 - 120mm ±0.3mm	HPR152i	UNLESS SPECIFIED COMPLY WITH THE [RoHS]	DRAWN: Huisheng Wu	Aug.16.06	CHECKED:		PART NO.			
1 - 5mm	±0.1mm	121 - 315mm ±0.5mm		FINISH:	CHECKED:		CHECKED:		SCALE	SIZE	DRAWING NO.	REV 2
6 - 30mm	±0.2mm	OVER 315mm ±0.8mm	ALL DIMENSIONS ARE IN MM	DO NOT SCALE DRAWING	APPROVED:				NTS	A4	EXPLODED_Hpr152i	PAGE 1 OF 3

Item Number	Component Description	Component Item Number	Qty
1	LOGO,HPR SERIES,,,,	PL-000440-GP	1
2	SCREW,TRUSS HEAD,M4X16,JHC030-00,,	SC-000099-GP	18
3	S/L WASHER,M9.7X22X0.5,,,	NW-000105-GP	2
4	GRILL,,,HPR152F,	CH-000476-GP	1
5	GASKET,1000X10X2MM,EVA B,,,	PL-000062-GP	5
6	SCREW WOOD,M4X20,BIND HEAD BZ,,,	SC-000100-GP	46
7	HORN,HF,HPR152F,,,	PL-000446-GP	1
8	EVA GASKET,5X500,,,,	PL-000066-GP	4
9	HEXAGON NUT,M6 X 10,,,,	SC-000087-GP	2
10	STUD,M6X34,BZ FOR QSC HPR,,,	SC-000103-GP	2
11	WOOFER,15",PAPER,FERRITE,CELESTION,FTR-3070C-T5452_GPE	SP-000081-GP	1
12	SCREW,M5X34,HEX-SOCKET,HEAD DIA 11XH5,BLK,	SC-000095-GP	8
13	FOOT A,,,,,	PL-000512-GP	1
14	FOOT B,,,,,	PL-000513-GP	1
15	FEET,END CAP,HPR,RUBBER, C,,	PL-000443-GP	1
16	FEET,END CAP,HPR,RUBBER, D,,	PL-000444-GP	1
17	SCREW,M5,HEXAGON-SOCKET,,,	SC-000092-GP	18
18	GASKET,FOR QBASS END CAP (1M),,,,	PL-000068-GP	4
19	ACOUSTIC WOOL,200X600X30,,,	MS-000074-GP	11
20	SCREW,M5X25,PAN HEAD,DIA 8XH2.5,BLACK,	SC-000094-GP	8
21	TOP HANDLE,FOR HPR,SIDE HANDLE,,	CH-000494-GP	2
22	RUBBER GRIP,FOR HPR SIDE HANDLE,,,,	PL-000072-GP	2
23	BOTTOM HANDLE,FOR HPR,SIDE HANDLE,,	CH-000523-GP	2
24	SCREW,M5X12,PH BLK ZN,,,	SC-000096-GP	4
25	HANDLE CAP,FOR HPR,,,,	PL-000076-GP	2
26	#16 AWG WIRE 770mm		1
27	ENDCAP,FOR HPR-2WAY/3WAY,,,,	PL-000069-GP	2
28	REAR HANDLE,FOR HPR,ENDCAP,,	CH-000493-GP	2
29	PLUG ENDCAP,FOR HPR 3WAY,,,,	PL-000073-GP	1
30	SCREW,PH,M5X85MM,,BLACK,	SC-000098-GP	8
31	TOP FRONT HANDLE,,,HPR,	CH-000690-GP	1
32	AMP MODULE ASSY,,HPR152i,120V,FULL RANGE, 15" 2-WAY	WP-152001-00	1
33	LED,3MM,BLUE SP,SLR343BB T 225419 ROHM,,,	QD-000312-GP	1
34	ENCLOSURE,,HPR152i,,,	SB-000057-GP	1
35	LED HOLDER,FOR HPR,,,,	PL-000479-GP	1
36	WIRE,BLACK&BLACK,26 AWG TWIN,,,1080MM,UL2468	WC-000420-GP	1

Item Number	Component Description	Component Item Number	Qty
37	WASHER,M6,IT,11.8X6.2,MF6003,	NW-000108-GP	2
38	GASKET,1300X10X4MM,EVA BK,,	PL-000063-GP	1
39	FOAM STRIP,MP1,406.4X6X4,SP8296,,	PL-000065-GP	1
40	GRILLE,GASKET,FOR QBASS,,	PL-000067-GP	4
41	RUBBER COVER,FOR HPR HANDLE HOLE,,,,	PL-000074-GP	4
42	COMPRESSION DRIVER,1.75",PETP FILM,FERRITE,CELESTION,CDX1-1745,T5453_GPE	SP-000082-GP	1
43	WOOD BLOCK,FOR HPR 2-WAY,,	MS-000075-GP	1
44	ME SCREW,4X30 6.8MM,BK-Z,JHB102,,	SC-000090-GP	2
45	BOTTOM FRONT HANDLE,,,HPR,	CH-000691-GP	1
46	WASHER,,M6 X 1 X 18,,	HW-000132-GP	6
47	SCREW,M6 X 49,,,,	SC-000145-GP	2
48	#16 AWG WIRE,UL1015 PIN,T65-6Y-2,,,,	WC-000419-GP	1
49	INPUT/OUTPUT PLATE (BARE), HPR152i	CH-000546-GP	1