

A D V A N C E D S Y S T E M S P R O D U C T S

RAVE

ROUTING AUDIO VIA ETHERNET

Application Guide

Please note: This document, published in 1997, does not incorporate the newer RAVE/s features, functions, and specifications. However, it is still useful as a RAVE overview and implementation guide.



Table of Contents

RAVE Digital Audio Router Application Guide

Routing: Getting audio from here to there and there, and there to over there ...	3
One problem, three solutions	3
The RAVE models and how they work	6
Glossary	7
How it works	7
Network design	9
Hardware and medium considerations	9
Network topology examples	10
Two nodes with a direct cable connection	10
Two nodes with a 100baseTX hub	10
Star topology	11
Distributed star topology	11
Longer distance through fiber	12
Network limitations	13
And the exceptions to the rules ...	16
Sample applications	16
Stadium	16
Airport terminal	18
Convention center	19
Broadcast facility upgrade	22
RAVE peripherals	23
QSC FE hubs	23
Latency and audio	24
Sound in free space	25
Synchronization with video	25
Specifications	26
Appendix	27
Address & Telephone Information	28

RAVE Application Guide

Unless you're working with a very small sound system, at some point you'll probably have to deal with routing audio signals, that is, getting audio from someplace to someplace else in real time, typically via wires. There are several ways to do this, and the cost, reliability, performance, and ease of use will be greatly affected by the method you use.

The latest (and we think, greatest) way to route audio is digitally, over a 100 megabit-per-second network, using RAVE digital audio routers from QSC Audio. This applications guide will help you decide where and when to use a RAVE network, and how to design it.

Routing: Getting audio from here to there and there, and there to over there ...

There are a number of ways of getting multiple audio signals from one place to another. The simplest way from Point A to Point B is by direct wire, as long as the distance is reasonable and there's no need to quickly change the routing. Examples of this include a multi-channel snake, or perhaps a small group of audio channels sent via individual cables through a wall from one room to an adjacent room.

The solution gets more complex as you add more sources, destinations, or both, particularly if you need to keep a high degree of flexibility in the configuration. In fact, a system using the direct wire method can grow geometrically as the number of sources, destinations, or channels increase.

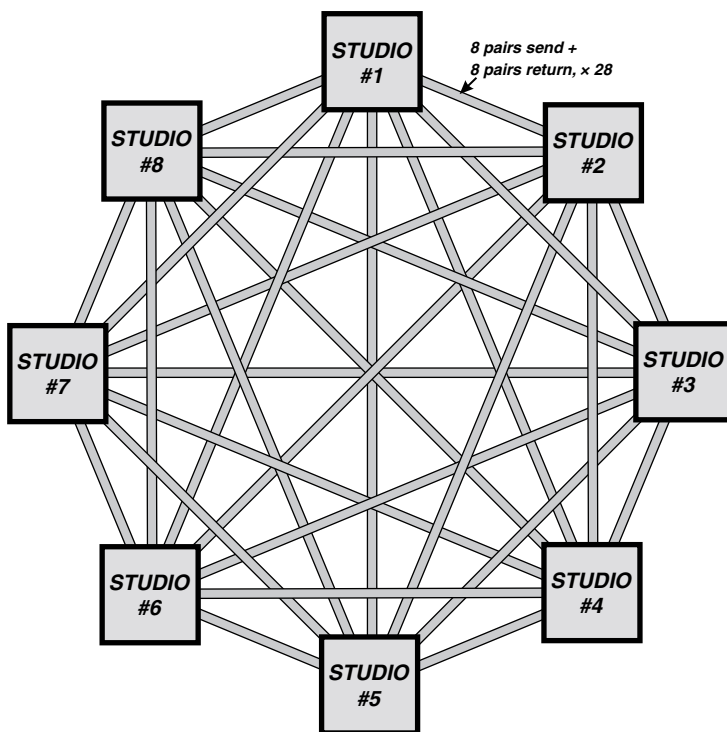

When routing many channels among many sources and destinations, direct point-to-point wiring is needlessly complex and costly.

ONE PROBLEM, THREE SOLUTIONS

To illustrate this phenomenon of increasing complexity, let's look at a theoretical but admittedly far-fetched job (hey, those "a train bound for Philadelphia leaves New York traveling 70 miles per hour" math problems in school had only a loose connection to reality, too, but they taught you the concept): let's say you had a site with eight audio facilities—production studios, equipment rooms, control rooms, whatever—and each one had to be able to send and receive eight channels of audio to and from any of the other facilities.

Point-to-point

This diagram shows the basket-like complexity of a point-to-point direct-wire solution to the problem. There are 16 shielded pairs of audio cables between every possible pair of rooms, and there are 28 possible combinations of rooms—a total of 448 individual cables. Imagine the labor involved to pull that many

cables and connect them to patch bays in each location. Imagine the likelihood of wiring errors and ground loops, and the susceptibility to EMI. On top of that, each room would require eight distribution amps. Hopefully, you'll never need to move or rearrange anything. It's an unnecessarily complicated, difficult, and expensive way to go.

Crosspoint routing

Another solution is the crosspoint router. It takes the eight channels of audio from each room to a central switching box and distributes them to whichever other rooms request the audio. The wiring complexity is much more manageable than with the direct-wire technique, but there are still 128 shielded pairs to connect, plus eight sets of control lines. And there is still the risk of ground loops and EMI.

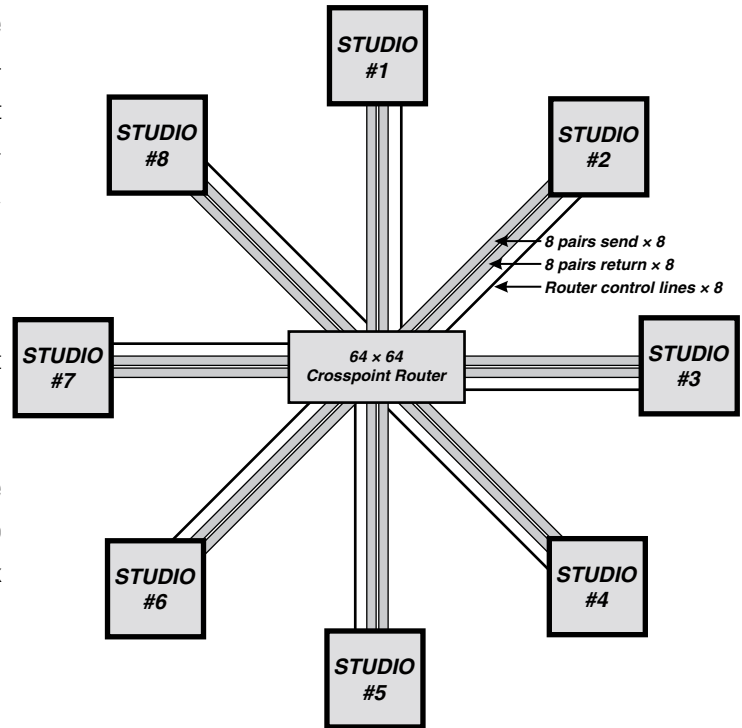

Crosspoint routing is a better solution than point-to-point, but it still has its drawbacks

Digital routing, using RAVE

The third solution is using RAVE digital audio routers, which use a 100baseTX Fast Ethernet medium to transport as many as 64 channels of audio over singular CAT5 unshielded twisted pair (UTP) network cable. Unlike the direct-wire approach, wiring needs in a RAVE system vary more or less directly with the number of locations you're routing audio to and from. In the system shown here, there are eight rooms, so there are eight wires, each connected to a RAVE 188, which sends eight channels and receives eight channels. Add a room? Add a wire and a RAVE unit. Run out of ports on the hub? Add another hub. Very simple.

Unlike the crosspoint router, the RAVE system is not centralized. All audio channels are available anywhere anytime on the RAVE network. The hub merely distributes the audio data among all the RAVE units.

An additional benefit is that the RAVE network distributes audio in the digital domain (48 kHz sample rate, 20 bits uncompressed) and is thus *free from ground loops*, and it enjoys a high immunity to noise and EMI. Certain RAVE models have AES3-format (AES/EBU) digital audio inputs and/or outputs, so you can route audio freely among analog and digital devices without interim conversion.

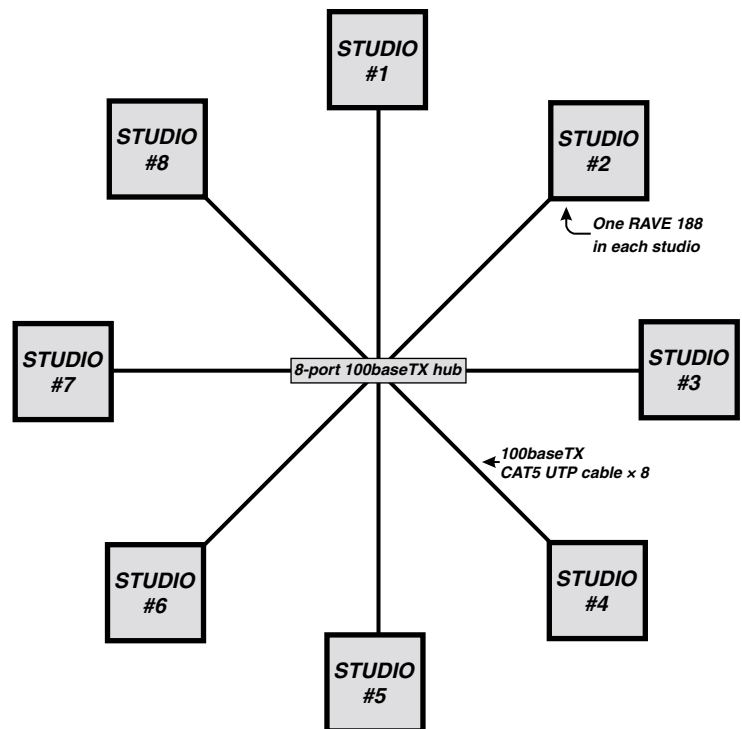

A RAVE digital audio routing network uses a central hub and reduces wiring requirements down to just a single network cable to each location.

In review, here are the three routing solutions we've looked at.

DIRECT WIRE

Complexity: For all but the simplest, Point A-to-Point B situations, terrible

Wiring material cost: High, and increases geometrically with added drops

Wiring labor cost: High, and also increases geometrically with added drops; high likelihood of errors

Reliability: Highly prone to ground loops and EMI

Ease of use: Difficult

Routing: Individual channels

Expandability: Not advisable

Distance: Depends on conditions; a practical limit might be a couple hundred feet, although longer distances are possible with suitable precautions

CROSSPOINT ROUTER

Complexity: Reasonable

Wiring material cost: Moderate to high

Wiring labor cost: Moderate to high

Reliability: Susceptible to EMI; may be prone to ground loops; unlikely to have redundant capabilities

Ease of use: Good

Routing: Usually by individual or pairs of channels

Expandability: Possible, depending on the capacity of the router

Distance: Depends on conditions; a practical limit might be a couple hundred feet

RAVE DIGITAL AUDIO ROUTER

Complexity: Very simple

Wiring material cost: Very low; might even already be installed

Wiring labor cost: Very low

Reliability: Free of ground loops; highly immune to EMI; capable of redundant operation

Ease of use: Good

Routing: Blocks of 8 audio channels

Expandability: Easy; up to 64 transmitted audio channels, but can accommodate any number of receiving devices

Distance: With CAT5 UTP cable, up to 100 meters (328 feet) between hub and RAVE unit; with 100baseFX optical fiber, up to 2 kilometers (1.24 miles) under certain conditions

The RAVE models and how they work

There are currently six RAVE models, and each one handles 16 audio channels. Three have analog inputs, outputs, or both, and the other three are digital, using the AES3 (also known as AES/EBU) format. The AES3 digital inputs and outputs are dual channel or stereo.

The models are:

- RAVE 88** Four digital (AES3) inputs + four digital (AES3) outputs
- RAVE 81** Eight digital (AES3) inputs
- RAVE 80** Eight digital (AES3) outputs
- RAVE 188** Eight analog inputs + eight analog outputs
- RAVE 160** 16 analog outputs
- RAVE 161** 16 analog inputs

The main functional differences among the models lie in the different I/O sections, as these block diagrams show. Analog units have internal jumpers for setting operating levels; details are in the RAVE User Manual.

RAVE units use detachable power cords, and their internal power supplies will automatically adapt to any AC line voltage from 90 to 240 volts.

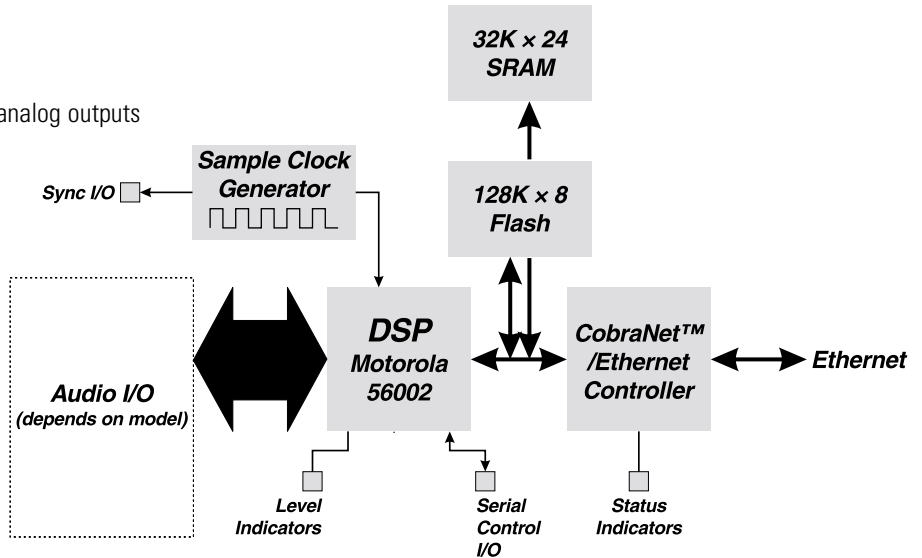

Internal block diagram of a RAVE unit; chief difference among the different models is the audio I/O (below)

Each RAVE unit has an RJ-45 jack on its rear panel for connecting 100baseTX Category 5 (CAT5) network cable. Audio inputs and/or outputs are also on the rear panel, as is an RS232 port for transmitting serial data over the RAVE network from one RAVE unit to another. A pair of BNC jacks provide a sync output and a “slave” input. More details on the “slave” feature follow later in this book.

You can use RAVE units in any combination that is useful to you. If you need to take 16 analog signals in one location and send them elsewhere to digital inputs on a tape recorder, for example, you only need to make sure you have the appropriate RAVE models—in this case, a RAVE 161 and a RAVE 80—to do the job.

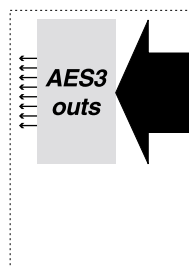

RAVE 80: 8 AES3 outs

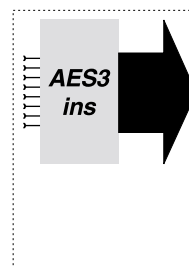

RAVE 81: 8 AES3 ins

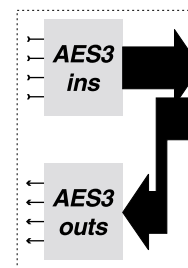

RAVE 88: 4 AES3 ins + 4 AES3 outs

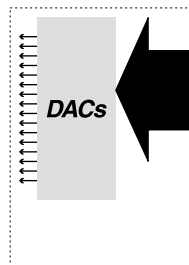

RAVE 160: 16 analog outs

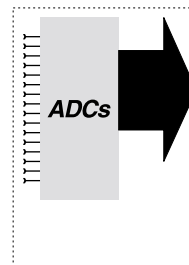

RAVE 161: 16 analog ins

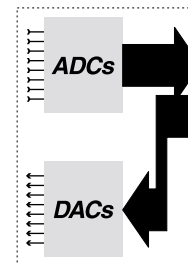

RAVE 188: 8 analog ins + 8 analog outs

GLOSSARY

Below are some terms used in this manual that might not be familiar to all RAVE users.

AES3—A technological specification for inter-device conveyance of a dual-channel (stereo) digital audio signal. Also called AES/EBU.

Crossover cable—A type of twisted-pair Ethernet patch cable, but somewhat analogous in function to a null modem cable. Unlike a normal patch cable, however, the transmit and receive wire pairs are swapped at one end, permitting a direct connection of two nodes without a hub in between. A crossover cable is also suitable for cascading hubs that don't have an available uplink port. It also has nothing to do with an audio crossover.

Network channel—A RAVE network group of eight audio channels, with a channel number designated by a switch on the sending unit. Don't confuse this term with actual audio channels. A RAVE network multiplexes eight audio channels onto a single network channel and routes the entire network channel as a whole. A receiving RAVE unit set to a particular network channel will output all eight of the network channel's audio signals.

Uplink port—A special port on a hub, used for cascading to another hub. Usually it's offered in tandem with a normal port so you can use one or the other, but not both. For example, a 5-port hub with an uplink allows you to connect to five nodes via the normal ports, or to four nodes via normal ports plus one hub via the uplink port.

HOW IT WORKS

Ethernet networks are most often used for computer systems; a typical application would be in an office with servers, workstations, and shared printers. These devices use the Ethernet medium in an unregulated, non-deterministic way. This means that they transmit data messages (called "packets") only when necessary, and the length of the messages may vary depending on the sending device and on the type and amount of data being sent. Each device, or node, on the network that has a message to send waits until there is no traffic, then sends it. If two or more nodes try to send messages at the same time, a collision occurs; each node then waits a random length of time before trying again. In this type of application, reasonable latency (the length of time from when the transmitting node has a message ready to send, to when the receiving node actually receives it) is not a problem, since a second or two delay in the transmission of a print job or an e-mail message won't have any noticeable effect.

Audio signals (especially multi-channel), however, generally can't tolerate a delay of even a significant fraction of a second, or even worse, a varying, unpredictable delay. This would cause glitches, dropouts, noise, and other nasty and undesirable artifacts in the final audio signal.

Therefore, the CobraNet™ technology used in a RAVE system employs a regulated, deterministic system of packet timing to ensure consistent and reliable transmission without dropouts or glitches. The RAVE devices on a common network will automatically negotiate the time slots among themselves; one unit will act as the "conductor" and broadcast a clock signal over the network to synchronize all the other RAVE units. For efficiency, the sample data from eight audio channels are grouped together in each packet.

Network design

Because a RAVE network uses a 100baseTX Fast Ethernet medium, you would generally use the same approach to designing the RAVE network as you would for a computer network.

There are several ways to configure a RAVE network, from very simple to relatively complex. The number of RAVE units in the network, where they are located, and your future expansion plans will determine what net topology would be best. The same techniques you would use in designing a conventional 100-Mbps Fast Ethernet will assist you in designing a RAVE network.

HARDWARE AND MEDIUM CONSIDERATIONS

RAVE units can use unshielded twisted pair wiring, but it must be at least Category 5 quality. Anything less may cause unreliable operation of the network, if it runs at all. Fortunately, most new Ethernet cable installations in buildings use Category 5 cable.

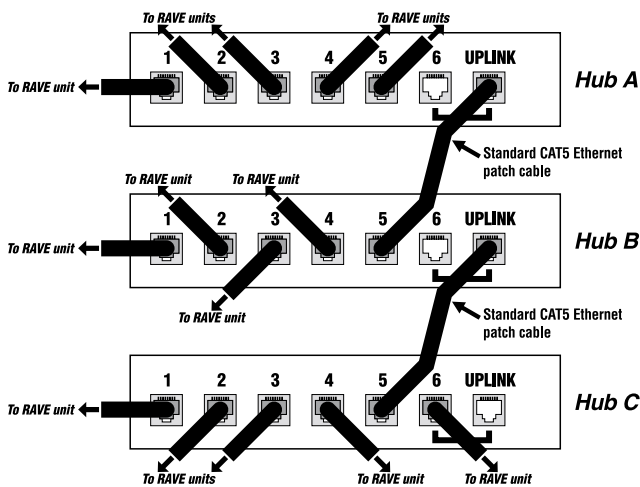

Cascading hubs with uplink ports

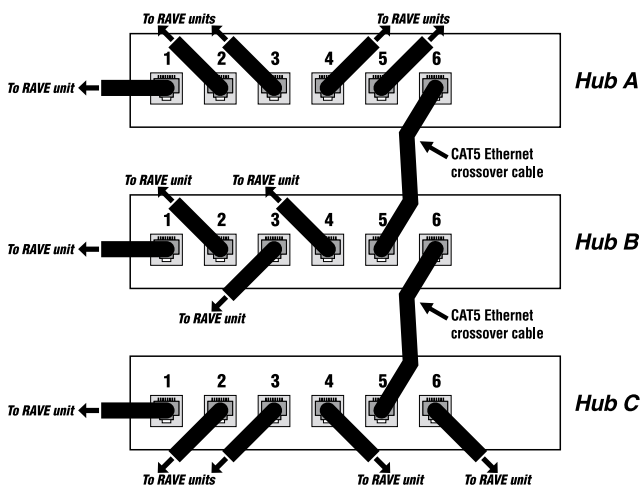

Cascading hubs without uplink ports, using crossover cables

Most RAVE networks will require one or more hubs, which must be compatible with 100baseTX Fast Ethernet. The next chapter will show how these hubs are used. A hub is primarily a repeater with multiple ports; any data that comes into one ports gets simultaneously distributed to all the other ports. A RAVE network will not work with the more common 10baseT hubs, which can only handle 10 megabits per second. Fast Ethernet hubs also cost more than the lower-speed versions, but like any other computer equipment, the performance-to-price ratio is continually getting higher and higher. In fact, whatever you spec today, you'll probably find an even better deal next month or even next week. At some point, though, you have to say *this* is what you need *now*, and go with it.

Most hubs have a port for uplinking or cascading to another hub. So if you have a six-port hub, for example, with all six ports connected to RAVE units, and you need to add a couple more RAVE units to the network, you don't need to replace the original hub with one having more ports. All you need to do is add another hub, connect it via an uplink port to the other hub, and hook up the new RAVE units. If your hubs have no uplink ports, you can do the same thing by using a crossover cable to interconnect the hubs.

Fast Ethernet techniques for operating over longer distances (>100 meters from RAVE unit to hub), such as conversion to a fiber optic medium, are also compatible with RAVE hardware, although the RAVE units themselves connect only via 100baseTX cabling. As with hubs, higher performance is always becoming more available and more affordable.

Network topology examples

TWO NODES WITH A DIRECT CABLE CONNECTION

Advantages: very low cost; very high reliability; simple to implement

Disadvantages: limited to 100 meters (328 feet) total network size; no expandability; uses non-standard wiring of RJ-45 connectors on Ethernet crossover cable

The simplest and most direct RAVE network comprises two RAVE units connected by a single crossover cable. This network has only one segment, so the 100-meter limit applies to the segment and thus to the entire network. There are no hardware costs other than the RAVE units themselves and the cable for the interconnection. Also, there are few potential failure points. However, there is no way to connect additional RAVE units without resorting to adding a hub, and because a crossover cable isn't yet a common off-the-shelf item, you might have to wire it yourself.

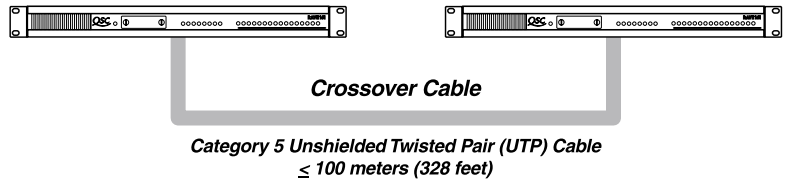

TWO NODES WITH A 100baseTX HUB

Advantages: greater network size—up to 200 meters (656 feet); high reliability; readily expandable; uses standard Ethernet patch cables

Disadvantages: higher cost

This network is similar to the previous one, but with a hub in between, breaking up the network into two segments which can each be up to 100 meters long. Yes, there is the added expense of a hub, and the addition of a critical active device affects the network reliability situation in a definite but extremely small way. But the network media can be simple off-the-shelf patch cables, which are much easier to buy ready-made than crossover cables. You can also easily expand the network by connecting additional nodes to the hub. Astute observers and those who have read ahead in the manual will notice that this network configuration is really just a star topology with only two nodes.

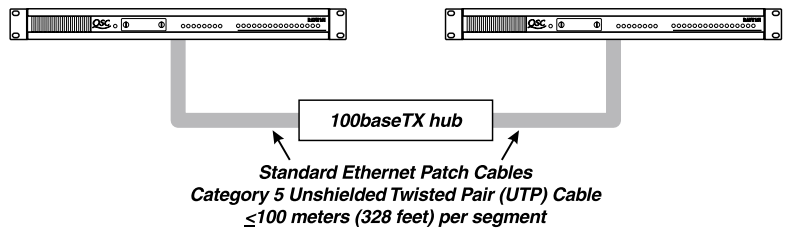

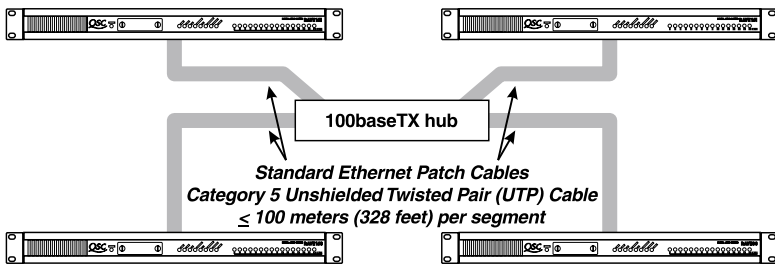

STAR TOPOLOGY

Advantages: greater network size—up to 200 meters (656 feet); high reliability; readily expandable; uses standard Ethernet patch cables

Disadvantages: higher cost

Add nodes—i.e., RAVE units—to the previous net layout and you have the classic star topology. This name comes from the hub being at the center and the nodes radiating out from it like the points of a star. It doesn't matter if the nodes are actually right next to one another while the hub is in another room—it's still a star topology. You can connect as many RAVE units as there are ports on the hub.

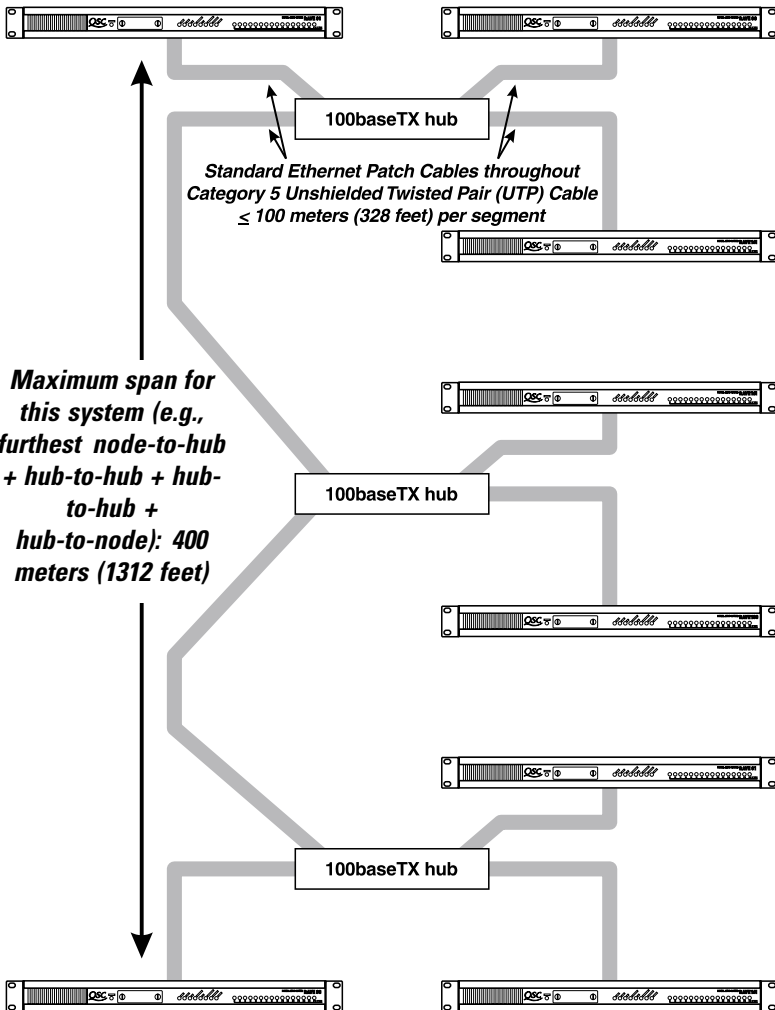

DISTRIBUTED STAR TOPOLOGY

Advantages: greater network size (see text); high reliability; readily expandable; uses standard Ethernet patch cables

Disadvantages: higher cost than smaller topologies

What do you do when you have more RAVE units than available hub ports? Add more hubs, of course. Most Fast Ethernet hubs now are stackable, either through an uplink port that lets you connect an additional hub to one already in the network, or through a backplane connection. The resulting network topology is called a distributed star, because it is made up of interconnected multiple stars.

The example shown here uses three hubs, so the maximum size of this particular CobraNet network would be 400 meters (1312 feet), allowing two 100-meter cable runs among the three hubs, plus 100-meter cable runs from the two outer hubs to their RAVE units.

You can expand the distances even further by daisy-chaining more hubs and cable segments. There are technical and practical limits to this strategy; see the section on network limitations for further information.

Longer distance through fiber

Sometimes a network may need to span a long distance but there is no practical need for hubs distributed along the way. The computer networking industry, on whom we're already relying for an economical and rugged transport medium, has an answer to this need also: fiber optics.

Data signals sent over optical fiber don't degrade as much as they do over copper wiring, and they are immune to induced interference from electromagnetic and RF sources, fluorescent lighting fixtures, etc. Consequently, a Fast Ethernet fiber optic network segment (100baseFX) can be up to 2 kilometers (6560 feet, or 1.24 miles) long, twenty times longer than what is possible with CAT-5 UTP copper wire.

Due largely to increased economies of scale, fiber optic cable pricing has become more economical in recent years, so even 62.5 μm multimode fiber is no longer painfully more expensive than CAT-5 UTP. However, because of the added cost of media conversion, it's usually most cost-effective to use fiber only when distance or electromagnetic conditions require it.

This illustration at right shows a simple 2-node network similar to the "hubless" one described before, except nearly all of the interconnecting UTP cable between the RAVE devices has been replaced by a couple 100baseTX-to-100baseFX converters and a length of fiber optic cable. The fiber optic medium allows you to increase the distance between the RAVE units by 2 kilometers. Some hubs, including certain QSC FE models, have both UTP and fiber ports and can thus perform the media conversion themselves.

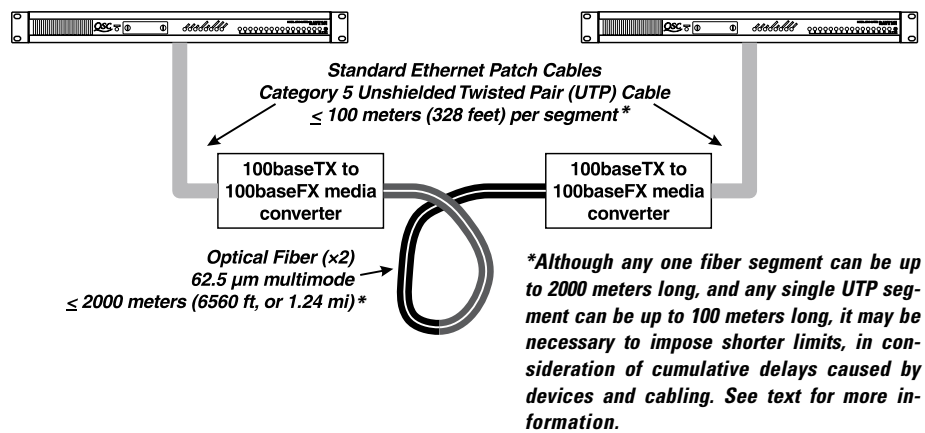

If you opt for the "hubless" topology shown in the illustration, beware of certain types of media converter that don't have a Fast Ethernet chipset for communication but instead "passively" convert electrical pulses to light pulses and vice-versa. Such converters might not pass the network start-up transmissions that the RAVE units and other Fast Ethernet hardware use to set up 100 Mbps communication, and the network will fail. If you encounter such a problem, there are several solutions you can try:

1. At one or both ends, insert a Fast Ethernet hub in the network between between the RAVE unit and the media converter.
2. Replace the media converters with ones that have true Fast Ethernet communication capability.
3. Replace the media converters with media-converting hubs, such as some of the QSC FE models.

The other network topologies described earlier also can be upgraded with optical fiber. This can be done with media conversion on individual network segments (opposite page, top) or by using fiber to interconnect hubs (opposite page, center), or combinations thereof. You can further simplify the networks by using hubs that have built-in media conversion capability, such as certain QSC FE models.

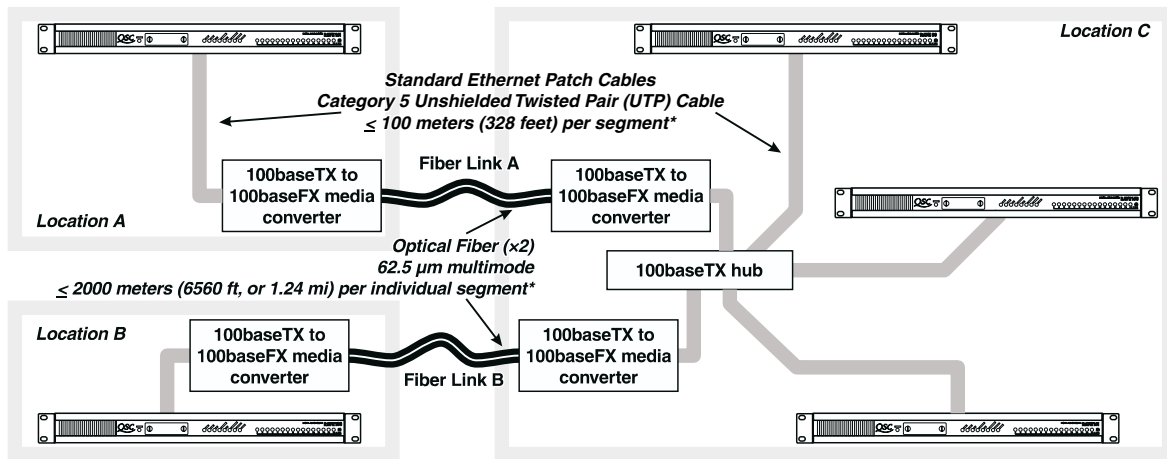

Using fiber on individual network segments

**Although any one fiber segment can be up to 2000 meters long, and any one UTP segment can be up to 100 meters long, it may be necessary to impose shorter limits, in consideration of cumulative delays caused by devices and cabling. See text for details.*

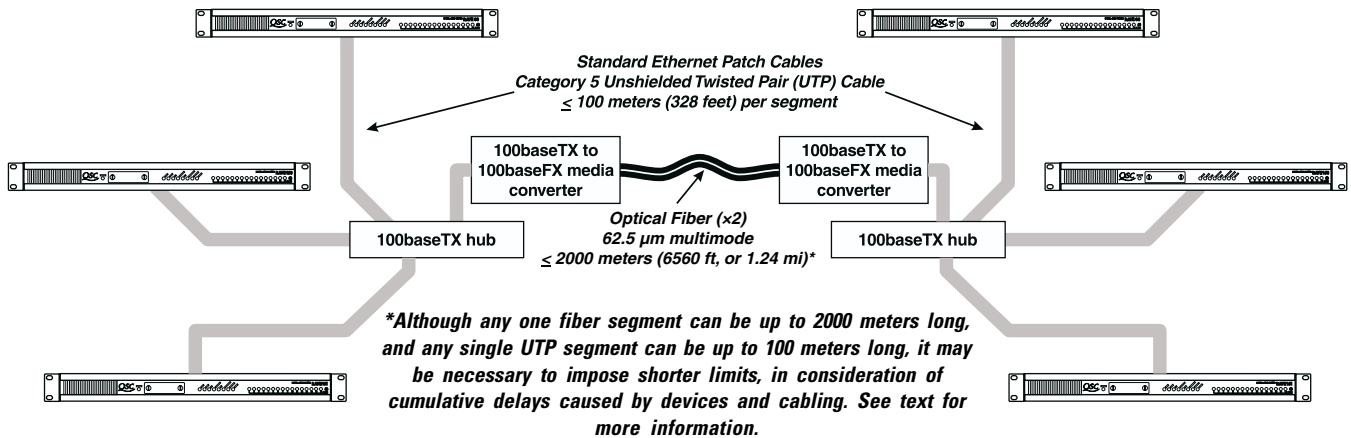

Using fiber to link distant hubs in a network

Bit periods

1 RAVE bit period (@ 100 million bits per second) = 10 nanoseconds

Maximum CobraNet span

2560 bit periods, or 25.6 microseconds

NETWORK LIMITATIONS

There are more possible network configurations than can be shown in this or any book, and as long as they use no switches or routers but otherwise meet Fast Ethernet standards, they generally will work with RAVE units. Keep in mind, though, that every hub, length of cabling, media converter, etc., delays the data passing through it by a small amount, and adding these to the system adds to the total delay time. CobraNet has a certain advantage over regular Fast Ethernet, however, in that its deterministic nature affords more tolerance of delay than unregulated, non-deterministic network traffic can handle: a network span or diameter of up to 2560 bit periods (with Fast Ethernet, 1 bit period = 10 nanoseconds), or 25.6 microseconds. Unless you are designing very large and complicated RAVE networks, though, you're very unlikely to reach these limits. For further guidance on designing large-scale networks, consult the CobraNet network guidelines on Peak Audio's web site: <http://www.peakaudio.com>.

As mentioned before, the maximum CAT-5 UTP cable length between two network devices—that is, between any RAVE unit, hub, etc., and any other—is 100 meters, or 328 feet. You can cover longer distances by using optical fiber, as mentioned earlier, or by running 100-meter lengths of UTP cable linked by Fast Ethernet hubs. The latter solution is practical mainly if you need, or are likely to need, RAVE units at the intermediate points, and it is possible only if you actually have power sources for all the Fast Ethernet hubs. Ultimately, the cumulative round-trip propagation delays of all the cables (typically 1.112 bit periods/meter) and intervening hubs (Class I hub: ≤ 140 bit periods; Class II hub: ≤ 92 bit periods; QSC FE hub: ≤ 46 bit periods) imposes a limit on how far you can carry this sort of configuration. See the CobraNet network guidelines at the Peak Audio web site (cited above) for further guidance, especially if you are designing a CobraNet network whose span approaches or even exceeds 1000 meters.

A fiber optic run of typical 62.5 μm multimode fiber can be up to 2 kilometers, or 6560 feet or 1.24 mile. Single-mode fiber, a much higher grade, offers better data pulse integrity but exhibits the same amount of delay as multimode. Therefore, it is not bound to a 2 km limit, but you must still consider its effect on total delay.

Although a RAVE network has a capacity of 64 audio channels—i.e., eight network channels, each with eight audio channels—there is no set limit to the number of receivers that a RAVE network will support, except that as you add more hubs and cabling, the data delays will increase.

This table shows the propagation delay in various devices and media used in a CobraNet network. Three different types of media converters are shown here, which should give you an idea of the wide range of performance parameters even among devices with similar functions. When calculating the maximum system span, you must add up all the delays involved, in cabling, hubs, converters, and the RAVE units themselves.

For example, a 100-meter length of CAT-5 cable means a delay of 111.2 bit periods, and a Class I hub will have up to 140 bit periods of propagation delay. A Class II hub has a better level of performance, so the delay is shorter.

The maximum span of a CobraNet network is 2560 bit periods, and as long as the sum of the propagation delays from any one RAVE device to any other RAVE device is less than that amount, the network will operate properly (if all other conditions are satisfactory, such as individual segment lengths being within limits).

Component	Round trip propagation, in bit periods
Optical fiber (multi-mode)	1.000/meter
CAT-5 cable	1.112/meter
DTE receiver (RAVE unit)	≤ 100
Class I hub	≤ 140
Class II hub	≤ 92
QSC FE hub	≤ 46
Digi MIL-180 media converter	48
Canary CFT-2132 100baseFX/100baseTX media converter	124
Transition Networks E-100BTX-FRL-01 media converter	133

If you exceed the maximum network diameter, CobraNet communication might not function reliably. In extreme cases, the network will simply stop functioning; more often, though, it will pass audio but also have noticeable artifacts, such as clicks.

That's why this network, despite its apparent complexity, will work ...

The maximum span of this network is from device A to device B. There are seven 100-meter lengths of CAT-5 cable (111.2 bit periods each) and six Class I hubs (up to 140 bit periods each) in between, plus the delay of the receiving RAVE unit (up to 100 bit periods) at the other end. These add up to a total of up to 1718.4 bit periods, which is well within the 2560-bit-period limit.

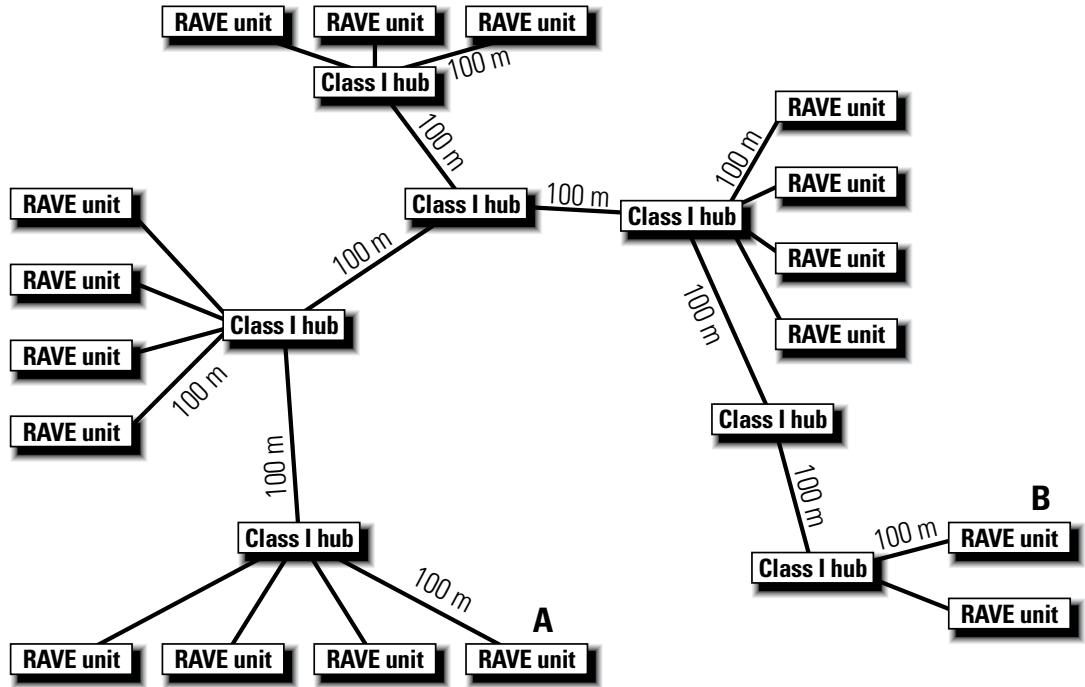

... but these seemingly simple networks won't.

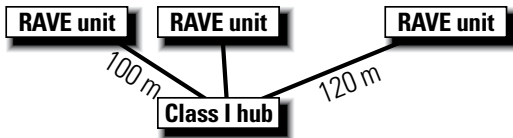

In this network, one of the CAT-5 cable segments is 120 meters long, which exceeds the 100-meter limit.

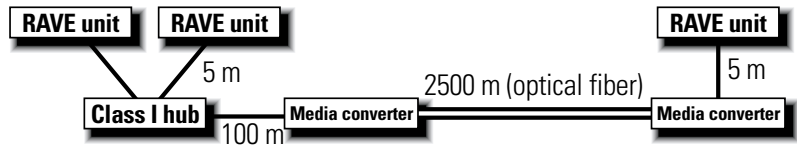

In this network, the maximum span comprises two 5-meter runs and one 100-meter run of CAT-5 cable (total of 120 meters, or 133.4 bit periods), a Class I hub (up to 140 bit periods), two media converters (let's say you bought the really nice ones, at 48 bit periods each—total, 96 bit periods), 2500 meters of optical fiber (2500 bit periods), and the delay in the receiving RAVE unit (up to 100 bit periods). This makes a total of up to 2969.4 bit periods, which well exceeds the 2560-bit-period limit and spells trouble.

AND THE EXCEPTION TO THE RULES ...

There is an exception to the maximum network diameter rule, which assumes that all points on the RAVE network can send and receive equally well—in other words, it allows bidirectional communication anywhere on the network. But if unidirectional communication is acceptable, you can exceed the 2560 bit-period limit as long as you follow all other distance rules (100 m for UTP segments, 2 km for multimode fiber, et al). For example, you could have a RAVE 161 or RAVE81 in one location, run a short UTP cable to a Fast Ethernet media converter, run single-mode fiber to another Fast Ethernet media converter, and then a UTP patch cable to a RAVE 160 or RAVE 80 in another place. In this situation, the fiber link could be 3, 4, or 5 kilometers long, or perhaps even longer, depending on the media converters.

Actual limits of unidirectional RAVE network operation haven't yet been determined. Because of the variables involved, QSC cannot guarantee satisfactory operation beyond the 2560 bit-period limit. But if you wish to try yourself, here are some tips that will increase your chances of success:

- Keep it simple. The fewer network channels being transmitted, the less effect the delay will have on operation and the better your chances the data will get through to its destination without problems.
- If possible, construct and test the RAVE network before installation: hook up the RAVE units to the hubs, media converters, cabling, and all other devices and media to be used, or their exact equivalents, and check to see that it all operates properly. This can save you a lot of time troubleshooting and configuring later.

Sample applications

The following sample application contrasts solutions using conventional analog techniques and using RAVE digital audio routers. You'll find that especially in the more complex systems, using RAVE devices typically requires much less cable, conduit, and labor cost.

STADIUM

The stadium in this example has a central control room, two remote equipment rooms located 1,000 feet from the control room, and one equipment room 300 feet from the control room. The distances used here are the lengths of the cable runs. The first solution uses conventional analog technology. The first RAVE solution (A) uses existing cable tray (possible because the optical fiber is immune to crosstalk and RF interference), while the second RAVE solution (B) uses new dedicated ¾-inch conduit.

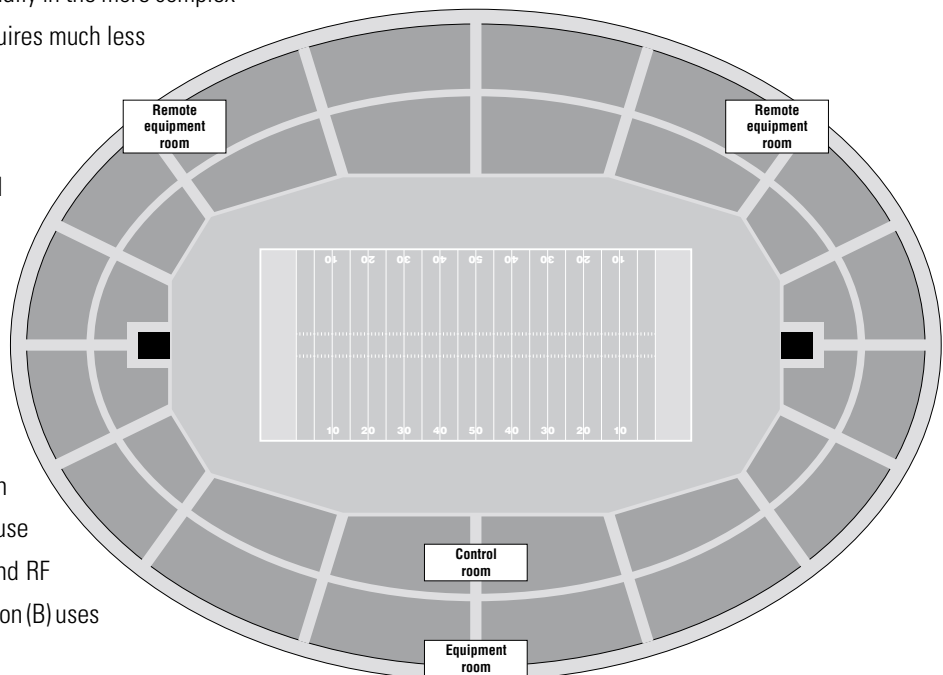

Stadium analog system

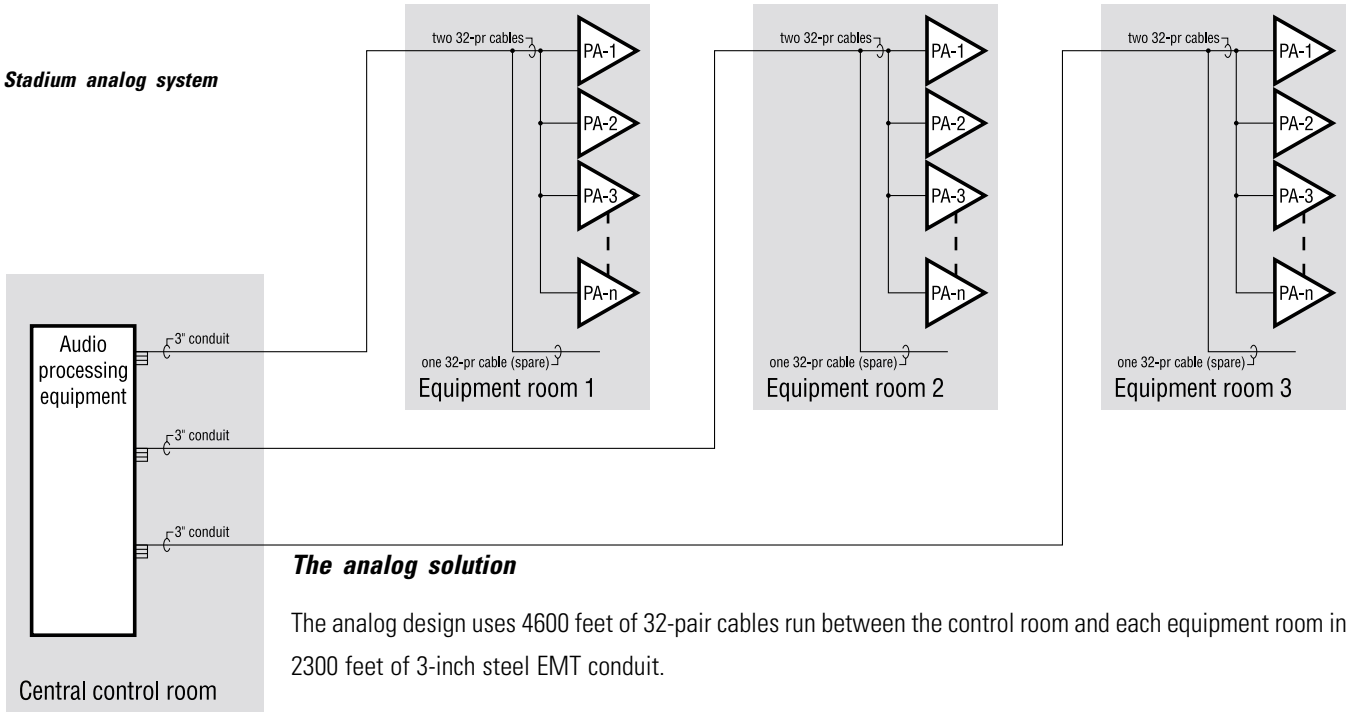

The analog solution

The analog design uses 4600 feet of 32-pair cables run between the control room and each equipment room in 2300 feet of 3-inch steel EMT conduit.

RAVE solution A

This solution uses existing cable tray, so the only conduit cost is 300 feet of 3/4-inch conduit from the cable tray to the equipment rooms. Cabling is 2300 feet of 4-strand multimode optical fiber.

RAVE solution B

Routed through 2300 feet of new 3/4-inch conduit is 2300 feet of 4-strand multimode optical fiber.

Stadium RAVE system (solution A shown)

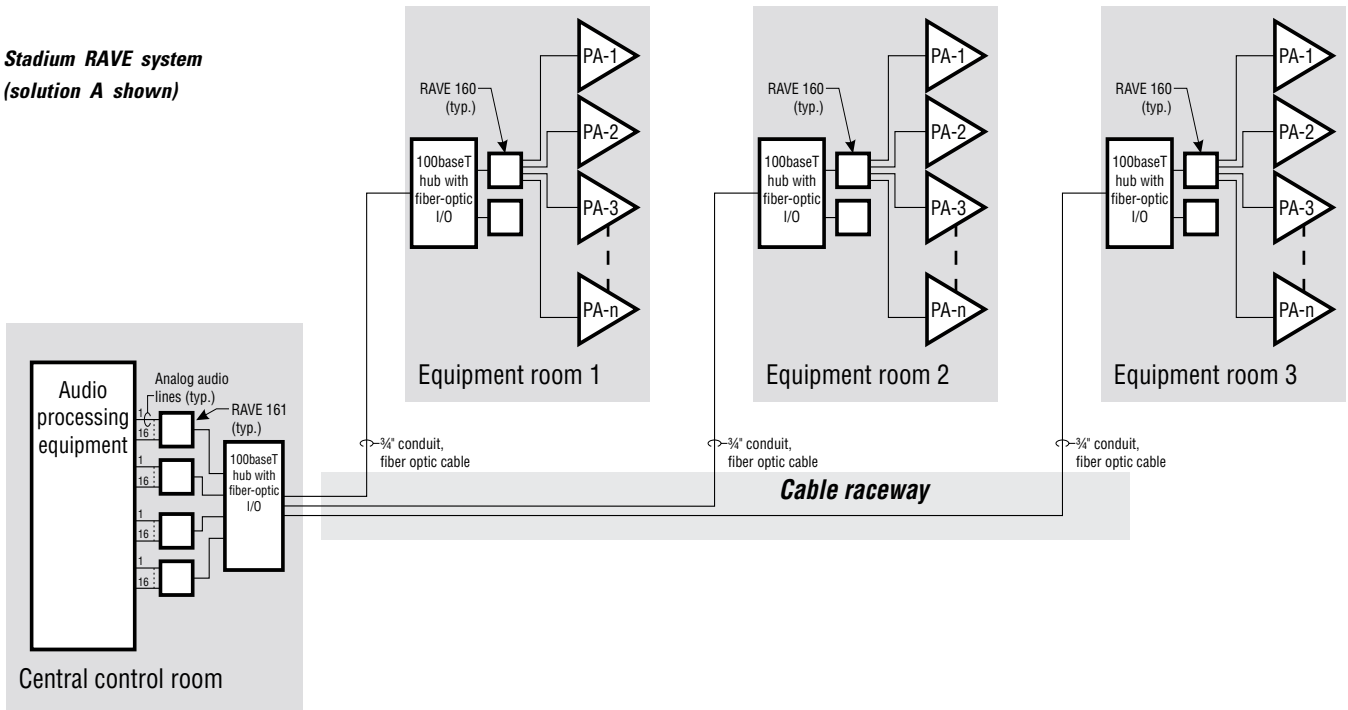

AIRPORT TERMINAL

The airport terminal in this example has a main equipment room which houses the signal processing equipment, along with four remote equipment rooms 250 feet apart along the length of the terminal. Each of the remote rooms serves four gate areas, and each gate area is served by four audio channels—two in, and two out. There are a total of 16 gates.

The analog solution

The analog system uses 1½-inch conduit in a direct run from each remote equipment room to the main equipment room, for a total of 2,500 feet. From each remote equipment room to each of the four gate areas it serves is a 150-foot run of ¾-inch conduit, a total of 2,400 feet. Audio cabling throughout is 16,400 feet of four-pair shielded copper wire.

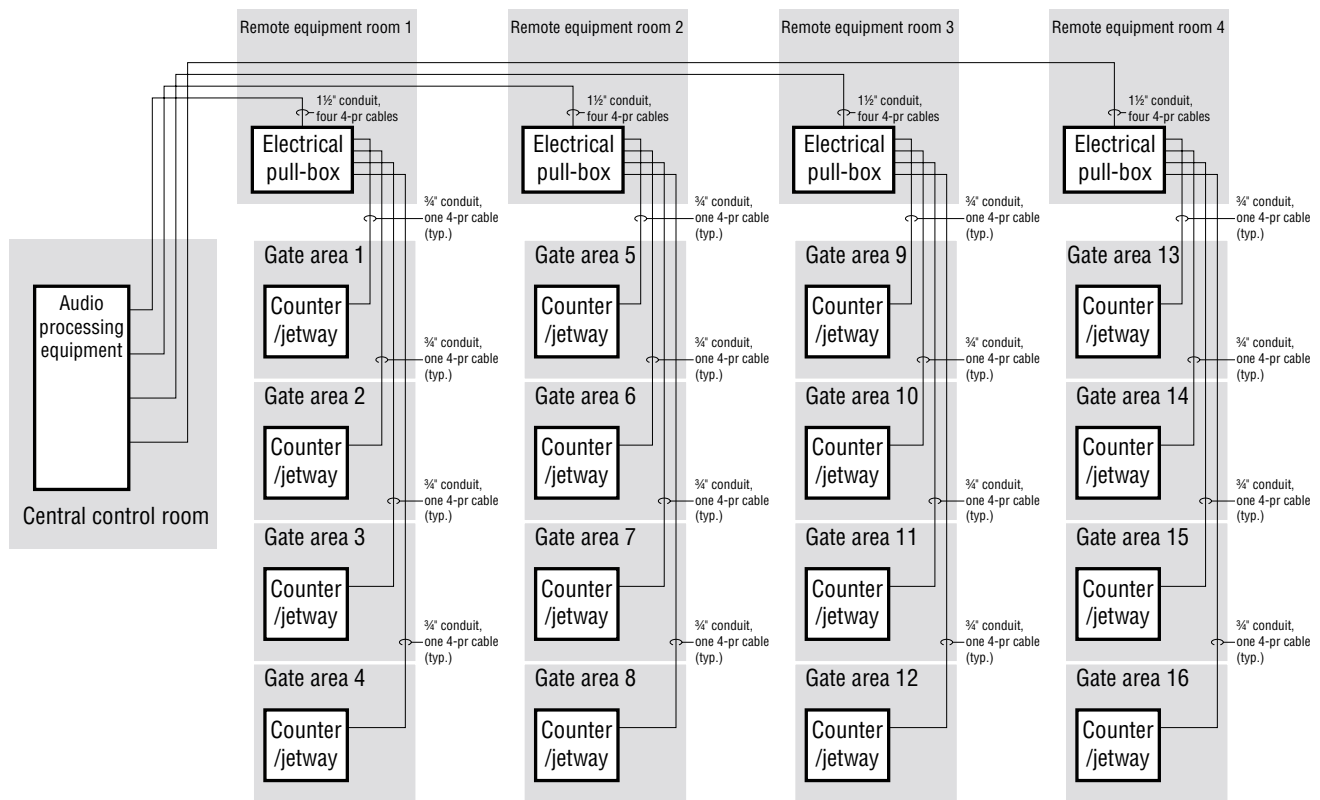

Airport analog system

The RAVE solution

A single ¾-inch conduit runs the length of the terminal to accommodate the fiber optic cable connecting the main equipment room with all of the remote equipment rooms. Three-quarter-inch conduit runs 150 feet long from the remote equipment rooms to the gate areas carry 4-pair copper wire, the same as in the analog design.

The total amount of ¾-inch conduit used is 3,400 feet. Also used are 2,500 feet of 4-strand multimode fiber and 2,400 feet of 4-pair cable.

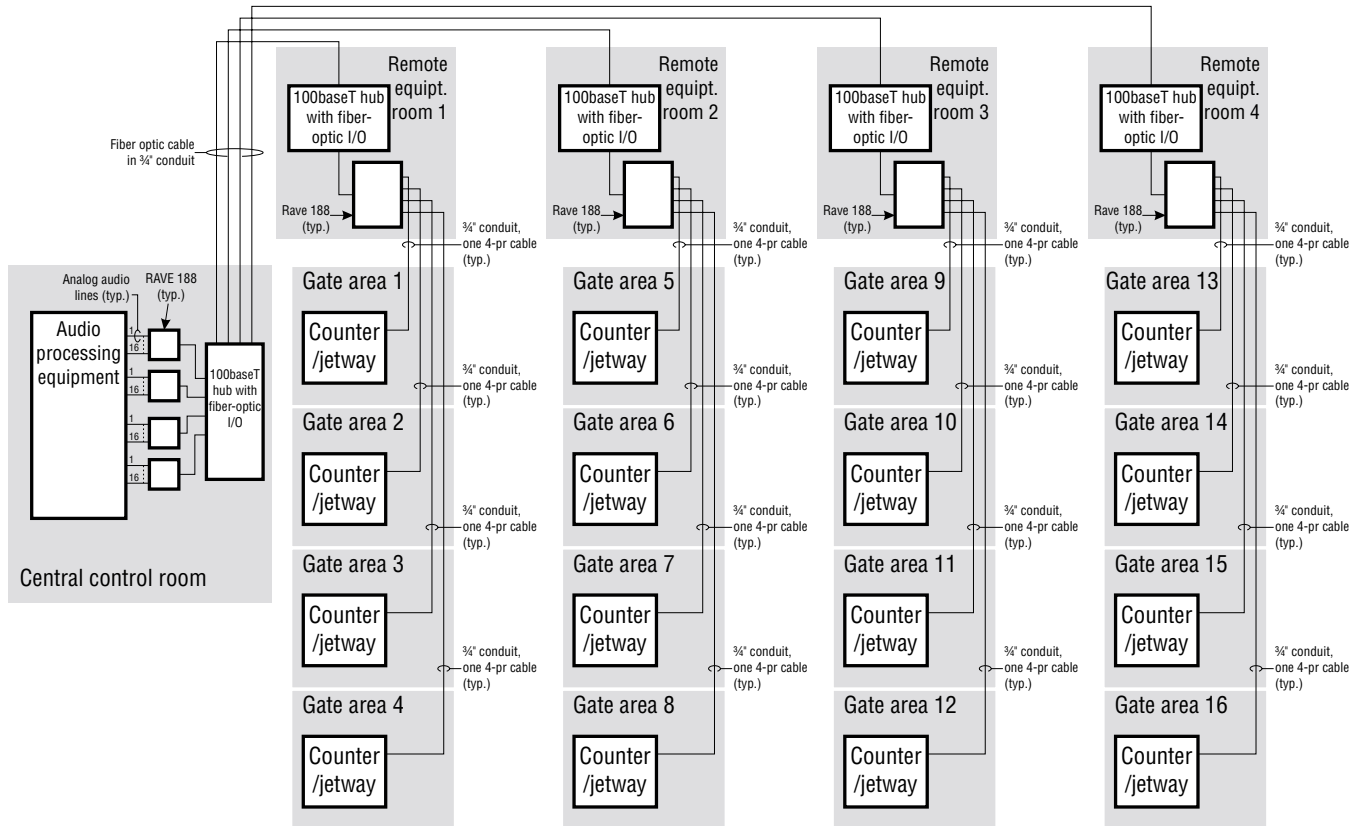

Airport RAVE system

CONVENTION CENTER

The convention center includes 40 meeting rooms, four ballrooms, and four exhibition halls. An equipment room is centrally located between the north and south meeting room corridors.

There are eight meeting rooms 300 feet (conduit length) from the equipment room, eight rooms 500 feet from the equipment room, 12 meeting rooms at 750 feet, and finally, another 12 rooms at 1000 feet from the equipment room. Each meeting room has a panel with six microphone inputs, two line inputs, and two line outputs.

There are four exhibition halls; the two central ones each have two input/output panels, and the two end halls have three panels each. Each panel includes 16 microphone inputs, four line inputs, and four line outputs.

Each of the four ballrooms has a panel which includes 12 microphone inputs, two line inputs, and two line outputs.

The analog solution

Meeting rooms: An eight-pair cable and a four-pair cable are run to a remote equipment closet from each of four meeting rooms in a 100-foot-long 1½-inch conduit. A 3-inch conduit is run from each remote equipment closet back to the equipment room. These conduits each carry 4 eight-pair and 4 four-pair cables.

Total materials: 5,750 feet of 3-inch conduit, 4,000 feet of 1¼-inch conduit, 27,400 feet of 8-pair shielded copper cable, and 27,400 feet of 4-pair shielded copper.

Exhibition halls: Each panel is home run to the central equipment room, an average of 1000 feet in a 2½-inch conduit. Total materials: 10,000 feet of 2½-inch conduit, plus 10,000 feet of 16-pair and 10,000 feet of 4-pair cable.

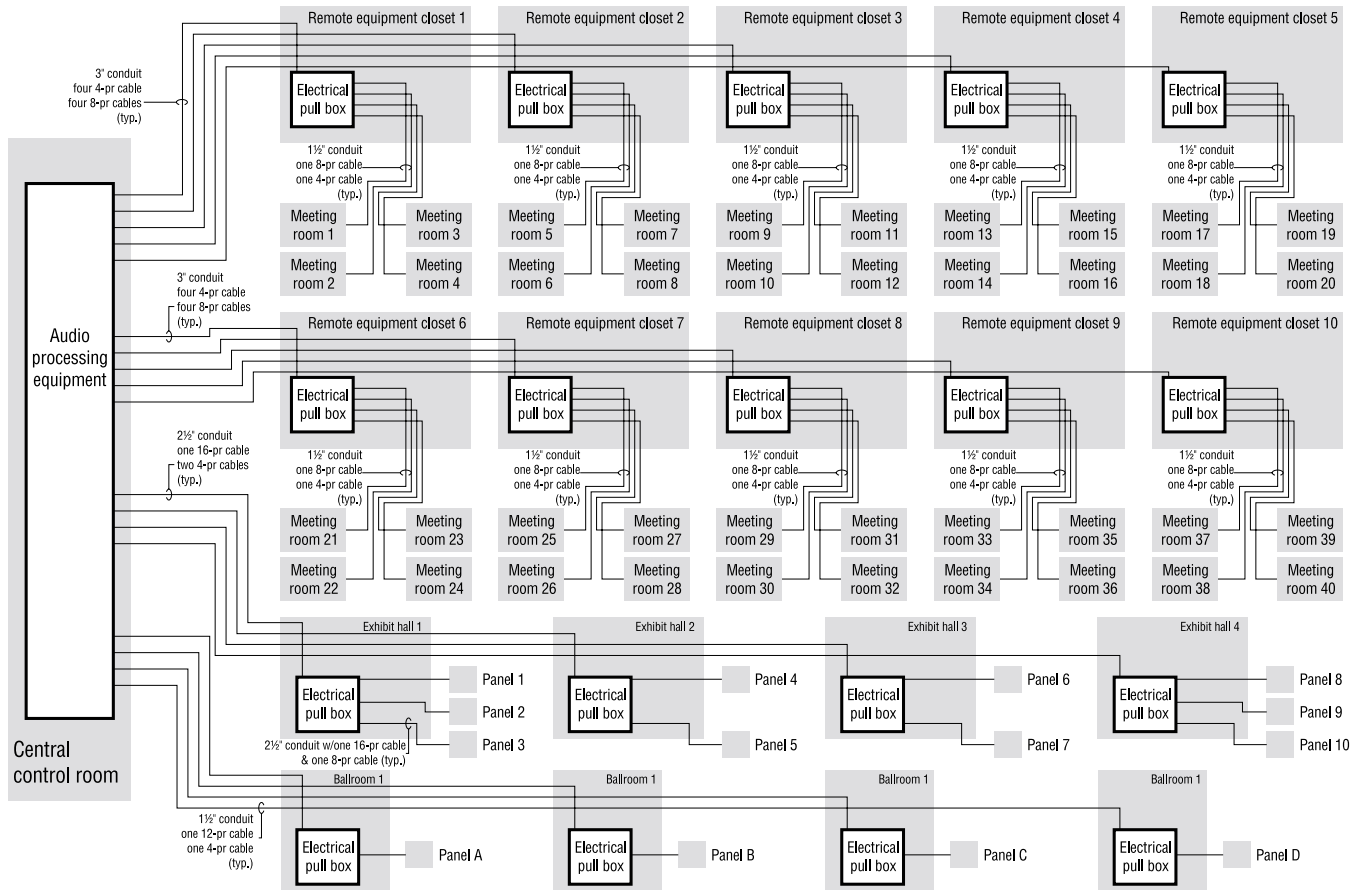

Convention center analog system

Ballrooms: Each ballroom has a 12-pair and a four-pair cable home run to the central equipment room in a 1½-inch conduit, an average run of 500 feet each. Total materials are 2,000 feet of 1½-inch conduit, 4,000 feet of 12-pair, and 4,000 feet of 4-pair copper cable.

RAVE

In the RAVE system design, the microphone preamplifiers will be located in remote equipment closets.

Meeting rooms: One 900-foot long ¾-inch conduit connects each of the north remote equipment closets and one connects each of the south equipment closets for the meeting rooms. This is a total of 1800 feet of ¾-inch conduit for the meeting rooms plus 4000 feet of 1½-inch conduit to connect the panels in the meeting rooms to the remote equipment closets. Total cabling is 1,800 feet of 4-strand multimode fiber, 4,000 feet of 8-pair copper, and 4,000 feet of 4-pair copper.

Exhibit halls: Each exhibit hall has one remote equipment closet with each two closets daisy-chained to a home run to the central equipment room. Each exhibit hall has one local panel (150 feet from remote equipment closet) and one or two other panels (500 feet from remote equipment closet). There is a total of 2,000 feet of ¾-inch

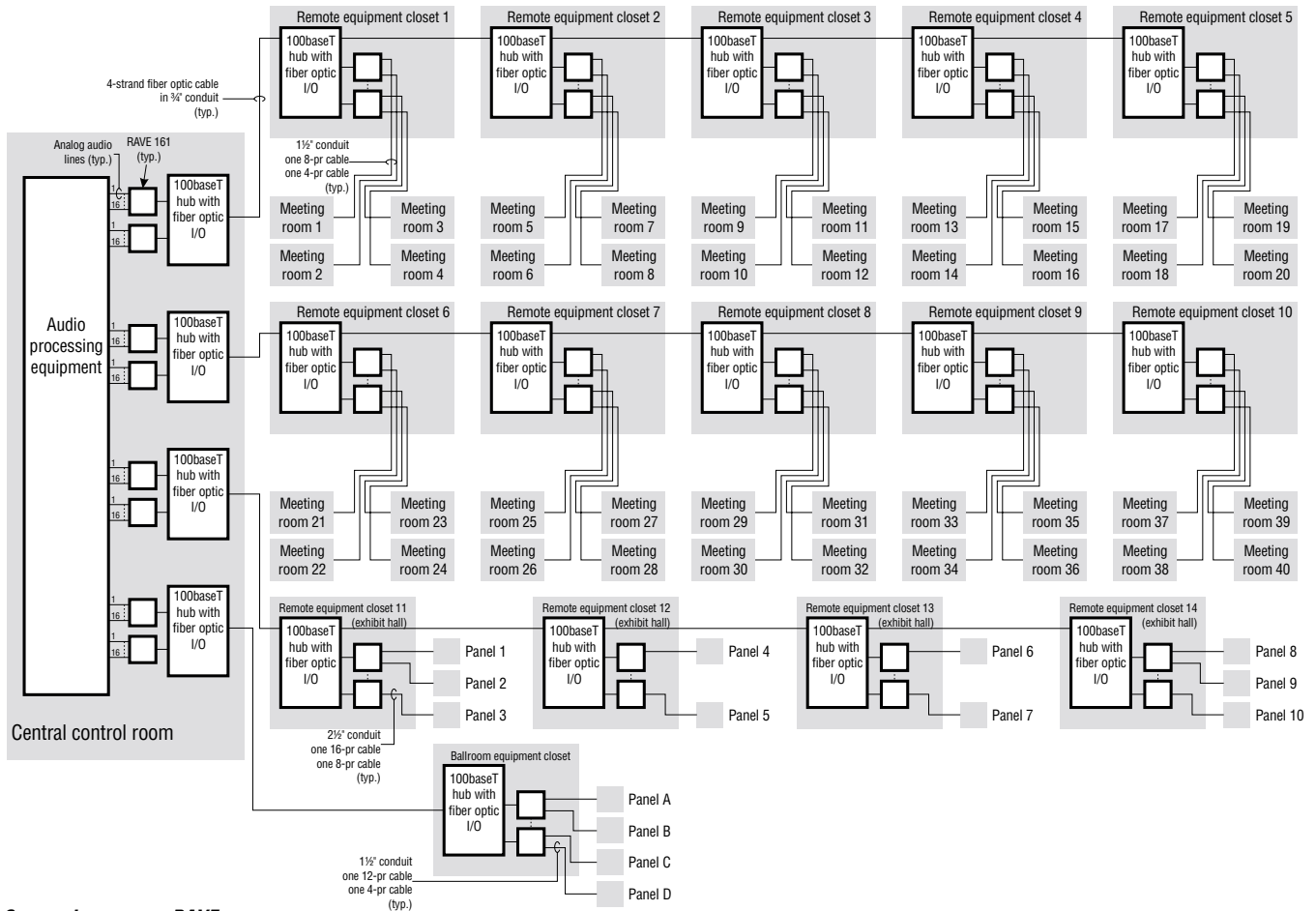

Convention center RAVE system

conduit, 2,900 feet of 2½-inch conduit, 2,000 feet of 4-strand fiber, 2,500 feet of 16-pair copper, and 2,500 feet of 8-pair copper.

Ballrooms: There is a 500-foot home run of ¾-inch conduit from the ballroom remote equipment closet to the central equipment room. Additionally, 600 feet of 1½-inch conduit (4 rooms at 150 feet each) connect between the remote equipment closet and the ballroom panels. Cable requirements are 1,250 feet of 4-strand fiber, 400 feet of 12-pair copper, and 600 feet of 4-pair.

BROADCAST FACILITY UPGRADE

An FM radio station has a studio facility located next to a hill; to gain antenna height, the station takes advantage of the hilltop's extra 300 meters in elevation for its transmitter location. But the distance between the studio and transmitter sites is slightly over a mile, making a studio-transmitter link (STL) necessary.

Currently, the studio's stereo air signal goes into an Optimod and a peak limiter, then into the stereo generator, where the composite audio is sent up to the transmitter site over an aging 950 MHz STL. Piggybacked onto the composite audio is a subcarrier carrying the audio-frequency analog control signals from the transmitter remote control. The FM carrier's 67 kHz SCA subcarrier carries encoded telemetry signals for logging of transmitter operation. The station's satellite downlink is located at the studio, but if it were atop the hill at the transmitter, the reception would improve and additional satellites carrying new programming would be "visible" to the dish.

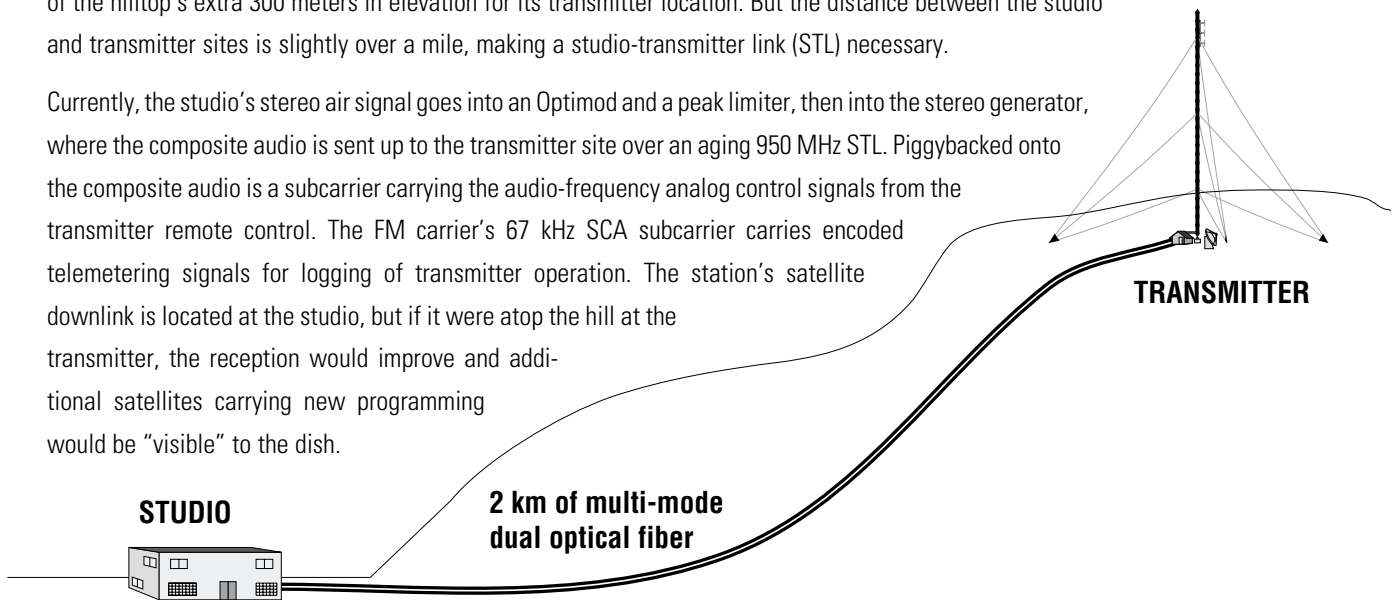

The design goals

The station management and chief engineer wish to accomplish several goals in this upgrade:

1. Replace the 950 MHz STL.
2. Relocate the station's satellite dish and receiver to the transmitter site to reduce shadowing by the hill.
3. Free up the station's 67 kHz SCA subcarrier, currently used for transmitter telemetry, for other service uses with revenue-generating potential.
4. Improve overall performance and audio quality.

The RAVE solution

The solution they chose uses a RAVE network with a fiber optic link between the studio and the transmitter building. The network will use a RAVE 188 in each building, providing line-level analog inputs and outputs, eight of each. At the studio, a QSC FE 3/1 hub, with three 100baseTX (UTP) ports and one 100baseFX (fiber) port, will convert the network media to fiber for the long hop to the transmitter building. Its extra ports will allow for the station to expand its internal routing system using additional RAVE units. The communication on the network will be bi-directional—not only will it carry the left and right audio channels, SCA audio, and the encoded-audio control signals for the transmitter and satellite receiver from the studio building to the transmitter building, but it will also carry stereo audio from the satellite receiver and the encoded-audio telemetry signal in the opposite direction. Additionally, audio channel overcapacity allows the chief engineer to make use of two channels for monitoring the audio going into the stereo generator for comparison with the off-air audio signal from the FM modulation monitor.

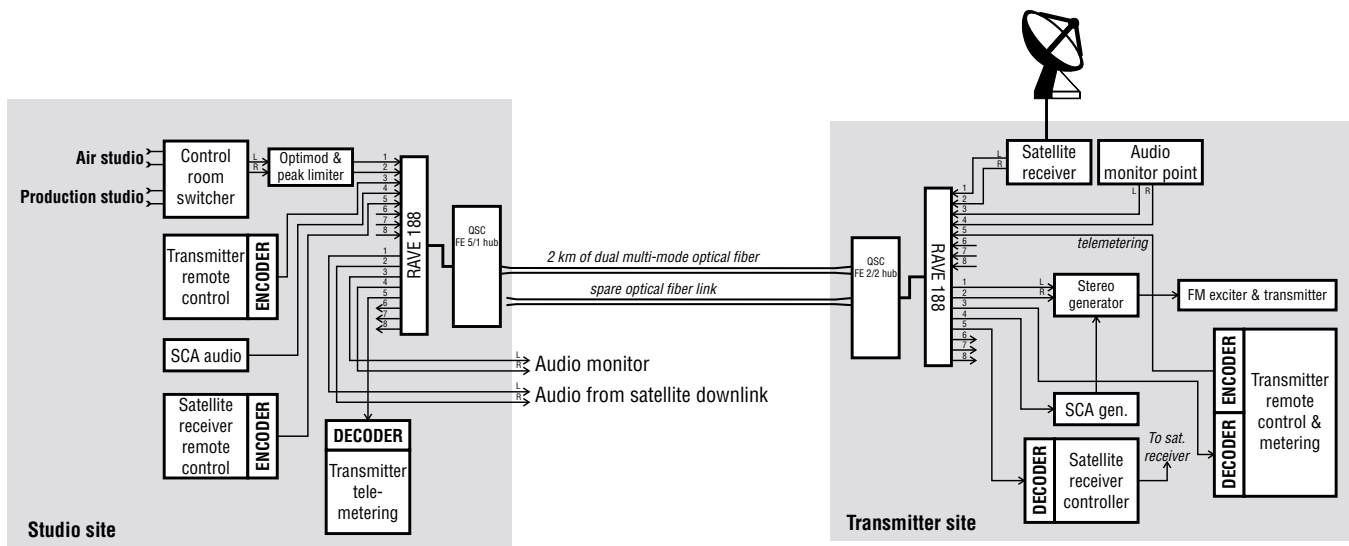

Using RAVE as a combined multi-purpose STL and TSL

At the transmitter site, a QSC FE 2/2 hub, which features two UTP and two fiber ports, will allow for a backup fiber cable to be installed later.

Studio ► transmitter		Transmitter ► studio	
Channel	Description	Channel	Description
1	Air signal, left channel	1	Satellite downlink, left channel
2	Air signal, right channel	2	Satellite downlink, right channel
3	Transmitter remote control signals (encoded audio tones)	3	Audio monitor, left channel
4	Leased SCA audio channel	4	Audio monitor, right channel
5	Satellite receiver remote control signals (encoded audio tones)	5	Transmitter telemetering (encoded audio tones)
6-8	Unused	6-8	Unused

Audio channel allocations

The table at left shows the allocation of the RAVE network’s audio channels.

The optical fiber is jacketed for outdoor use and will be strung on the utility poles that carry the AC service up to the transmitter site. Fortunately, fiber optic cabling is immune to the hum fields around the AC wires. To be relocated to the transmitter site is the stereo generator, which will feed the FM exciter directly. Also, the SCA generator will be

switched over from transmitter telemetering tones to a regular leased audio channel.

The present microwave STL has a THD spec of 0.7% at 100% modulation and an S/N ratio of 65 dB, so the superb audio performance of the RAVE network eliminates one of the weaker links in the chain.

Although the transmitter site has an emergency generator that automatically starts up in event of an AC power loss, the chief engineer plans to also use an off-the-shelf uninterruptible power supply. The UPS will power the RAVE 188, hub, transmitter remote control, and satellite receiver so they are unaffected by the several seconds of lag between the loss of AC power and when the generator is running and stable.

RAVE peripherals

QSC FE HUBS

As a convenience to RAVE users, QSC offers a series of seven Fast Ethernet hub models that feature especially low latency ($\leq 0.46 \mu\text{s}$; equal to ≤ 46 bit periods) and various combinations of 100baseTX and 100baseFX (multi-mode fiber) ports for built-in media conversion. The hubs are 1 RU high and feature an auto-sensing switching power supply that automatically adapts to AC service from 100 to 240 VAC.

Other features:

- Manufactured to QSC specifications by a leading network hardware manufacturer to work specifically with RAVE audio distribution networks
- Supported by QSC's full 3-year warranty
- Includes a switchable uplink port for cascading hubs
- Heavy-duty rack-mount chassis
- High-speed cooling fan for demanding environments
- Individual activity sensor for each port
- Overtemperature sensor with buzzer alarm

MODEL	TX ports (CAT5 UTP)	FX ports (fiber optic)
FE 5/0	5	0
FE 8/0	8	0
FE 3/1	3	1
FE 5/1	5	1
FE 2/2	2	2
FE 5/2	5	2
FE 2/4	2	4

Latency and audio

The latency (how long it takes for an audio signal to get from the input of a RAVE unit to the output of another RAVE unit on the same network) or propagation delay of a RAVE network is 6.3 milliseconds. What happens in that time? An analog audio signal has to go through an analog-to-digital converter first, and its digital data then goes on to a buffer, a temporary memory location. An AES3 digital signal doesn't need A-to-D conversion, so it goes right into the buffer.

The buffer briefly holds the 20-bit data from the audio channel while it gets lined up with the 20-bit data from the other seven audio channels in the block, which is assigned to a particular network channel. The RAVE unit adds identifying and managing bits to the data, and then when the block's turn to be transmitted comes around (as it does 48,000 times per second), the RAVE device sends the whole packet out onto the network and then immediately lines up the next packet.

The data traverses the network, traveling through UTP cable at almost the speed of light and through optical

fiber at even closer to the speed of light. Hubs and other intermediate devices have their own propagation delay and slow the data down by no more than one or two microseconds.

The receiving RAVE unit, when it sees a data packet with the identifier of the network channel it is set to, pulls that packet into its buffer, separates the data into all eight audio channels, and feeds the data directly to the outputs, if it's a digital unit, or to digital-to-analog converters if it's an analog one. And it does this 48,000 times per second also.

All this happens in 6.3 milliseconds. You might look at the latency specification and wonder how it will affect your system. It's a perfectly legitimate question. To determine this, let's first look at what the time interval equates to.

SOUND IN FREE SPACE

At an ambient temperature of 20° C (68° F), sound travels at a velocity of approximately 343 meters (1125 feet) per second, or 34.3 cm (13.5 in) per millisecond. Therefore, the delay inherent in a RAVE network is equal to the time it takes sound to travel 2.16 meters (7 feet 1 inch). If you use a RAVE network in a system for sound reinforcement, cinema sound, stadium/arena sound, etc., you might need to consider this delay when you design and set up the system, especially if you use any of the same audio program, routed both via a RAVE system and by direct wire, to cover any of the same acoustic space.

For example, a large concert sound system uses both a main speaker system for the near audience and a system of speakers for the outer reaches of the audience, delayed 150 milliseconds so it will be coincident with the sound from the main speakers. It uses a RAVE network to distribute sound to the delayed system, but not to the main system. The system engineer, therefore, will set the delay units for the outer system at 143.7 milliseconds, because the RAVE network itself has 6.3 milliseconds of delay.

SYNCHRONIZATION WITH VIDEO

When using audio and video together, it is vital that they stay synchronized with each other. Otherwise, the embarrassing effects of people's voices not matching the motions of their mouths, or of sound effects not coinciding with the visual clues of their events, could occur.

NTSC video uses 525 lines per frame at a frame rate of 29.97 Hz, so each line of video is 63.56 microseconds long. PAL and SECAM video use 625 lines at a frame rate of 25 Hz, so each line is 64.0 microseconds long. Thus, the delay caused by a RAVE network's latency represents only 99.1 lines of NTSC video, or 98.4 lines of PAL or SECAM video. These are respectively less than 1/5 and 1/6 of a frame, and therefore will not cause noticeable loss of synchronization between the visual and the audio programming.

Specifications

Analog Audio

Sample rate	48 kHz
A/D converters	20 bits
D/A converters	20 bits
Network transmission	20 bits
THD	0.007% worst case, 0.004% @ 1 kHz
Signal to noise	
RAVE 161 and 188 inputs:	104 dB typical; 102 dB worst case, 22 Hz–22 kHz
RAVE 160 and 188 outputs:	102 dB typical; 101 dB worst case, 22 Hz–22 kHz

Network

Data Format

Header	Standard Ethernet header
Packet trailer	4 byte CRC.

Network Capacity (without unregulated traffic)

100baseTX	64 channels
-----------	-------------

Unregulated Traffic

To maintain continuous maximum performance, we recommend that you do not share the RAVE network with other computer network devices. Gaps are inserted between each data packet to make the network robust to *limited* unregulated traffic. Recurring management traffic should not seriously affect the network. Large computer file transfers would likely cause audio dropouts.

Delay

Group Delay

Delay through network	6.3 milliseconds or less
-----------------------	--------------------------

Delay Variation

Guaranteed $\pm\frac{1}{4}$ sample periods ($\pm 5.28 \mu\text{s}$)

AC Power

90 to 264 VAC, 47 to 63 Hz.
No user selection of line voltage or frequency is required; the internal power supply automatically switches accordingly.

Appendix

ETHERNET CABLING

This diagram shows the pinout for standard unshielded twisted-pair (UTP) network cable. Both ends of the cable are wired identically.

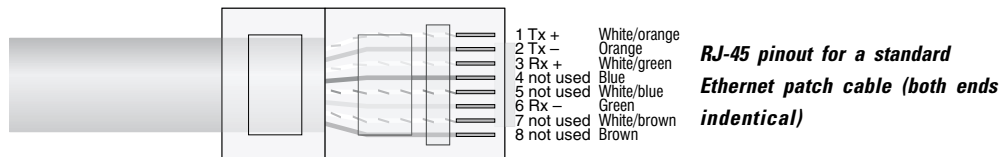

A crossover cable has the RX and TX wire pairs switched around at one end. There are only two likely situations that would require a crossover cable: to connect two RAVE devices directly, without a hub or other device in between; and to cascade hubs that don't have uplink ports.

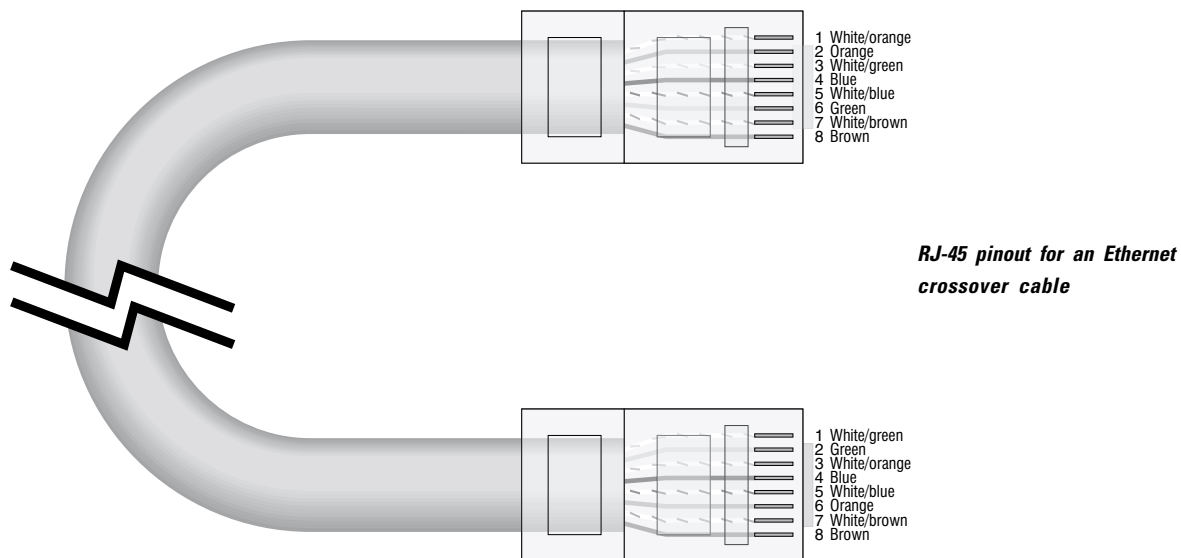

The wire in UTP cabling is twisted together in pairs. Rather than randomly choosing a wiring scheme for the networking cable, it is important to have the RX wires in one pair and the TX wires in another pair, especially in longer cable runs.

RS232 PORT INFORMATION

Pin assignments of 9-pin female D connector:

Pin 2: TX out

Pin 3: RX in

Pin 5: Ground

Pins 1 (DCD), 4 (DSR), and 6 (DTR) are tied together. Pins 7 (RTS) and 8 (CTS) are also tied together. DCE (receives on TD) operation; parity bit not transported.

Address & Telephone Information

**Address:**

QSC Audio Products, Inc.
1675 MacArthur Boulevard
Costa Mesa, CA 92626-1468 USA

**Telephone Numbers:**

Main Number (714) 754-6175

Sales Direct Line (714) 957-7100

Sales & Marketing

(800) 854-4079

(toll-free in U.S.A. only)

Technical Services (714) 957-7150

(800) 772-2834

(toll-free in U.S.A. only)

**Facsimile Numbers:**

Sales & Marketing FAX
(714) 754-6174

Technical Services FAX
(714) 754-6173



BBS/World Group:

QSC OnLine Technical Support

1200-14400 bps; 8N1

(714) 668-7567

(800) 856-6003

CompuServe

GO QSCAUDIO

ID: 76702,2635

World Wide Web

<http://www.qscaudio.com>



www.qscaudio.com

1675 MacArthur Boulevard, Costa Mesa, CA 92626 USA • Ph: 714/754-6175

"QSC" and the QSC logo are registered with the U.S. Patent and Trademark Office.
© QSC Audio Products, Inc.